



## Table of Contents

REQUIRED COMPONENTS .....	1
STRAPPING SIZE RECOMMENDATIONS .....	6
DISPLAY ALIGNMENT .....	7
SOLAR PANEL INSTALLATION.....	8
1820 8 X 11" BACK PANEL CLASSIC BOARD DISPLAY CABLE CONNECTIONS.....	12
1820 8 X 11" BACK PANEL PROGRAMMABLE DISPLAY CABLE CONNECTIONS .....	13
CONTACT INFORMATION – SALES AND SUPPORT .....	14

## Required Components

Following are the common installation methods, and a listing of the components that are required for each method. All components listed as end user supplied are readily available from electrical or traffic control equipment suppliers.

### ***Vendor supplied components:***

#### **Display System:**

- Display unit
- AC Systems include pole mounted power supply enclosure w/conduit connectors
- Mounting brackets and fasteners ( $\frac{1}{4}$ "-20x $\frac{1}{2}$ " BH Cap screws)
- Water tight flexible conduit
- Installation manual

#### **Solar Package:**

- Solar panel(s) (*usually drop-shipped from a solar panel distributor*)
- Display power cable
- Solar panel mounting bracket(s) (*Top mount bracket is standard – Side mount is available for light, telephone or other existing tall poles*); may be drop-shipped or sent directly from IDC
- Pole mounted battery box including charge controller (*including solar battery*)
- Conduit end fittings, (*included in battery box*)
- Solar power cable, (*to be cut and used as required*)

### ***End-user supplied components:***

#### **AC powered system – general recommendations for overhead drop:**

- 3" or larger pole recommended
- Frangible or break-away base & hardware if required (*we can supply or recommend*)
- Footing materials for frangible or break-away base if required
- $\frac{1}{2}$ " weather head or pole cap
- Sign strapping and strap installation tool (*see chart on following page for strap size recommendations*), heavy-duty tamper proof band clamps, or appropriate size u-bolts with back plates.

#### **AC powered system – Underground feed:**

##### **Pole:**

- 3" or larger pole recommended
- Frangible or break-away base & hardware if required
- Footing materials for frangible or break-away base if required
- Sign strapping and strap installation tool (*see chart on following page for strap size recommendations*), heavy-duty tamper proof band clamps, or appropriate sized u-bolts with back plates.

## Power feed options:

### Internal to pole (recommended)

The cleanest installation method is to use internal wiring with an entrance fitting going through the side of the pole a foot or two above the display housing location, on the side of the pole facing the display. If you contemplate doing this you will also need;

- 1 length ¾" conduit for burial as lead-in to pole base
- Pole cap
- ¾" entrance elbow to be mounted to the pole
- Fittings to go from this entrance elbow to the entrance elbow on the display – flex conduit is supplied but, you may want to consider IMC, EMT, or liquid tight conduit

### External to pole:

The simplest installation by far, and the method most often used, is with the use of external conduit which is strapped to the pole. For this type of installation, in addition to the above, you will also need:

- 1 length of ½" conduit suitable for the application (*recommended IMC*)
- 3 additional bands to attach the conduit to the pole

### Pole Mounted Power Supply Box

Supplied with 110 volt AC systems, converts AC power to 12 volts DC needed to operate the SpeedCheck sign. Liquid-Tight flexible metal conduit type LFMC and connectors are provided for hookup.



## Solar Powered System:

### Pole:

- For solar powered installations we recommend the use of at least a 4" pipe size pole as it will provide a solid platform that is capable of withstanding heavy wind loads with solar panels mounted. Based on your specific installation, number and size of solar panels, minimum wind design requirements for your area, local preference, etc., a traffic engineer or traffic control equipment specialist may conclude that something else is more appropriate for your application.
- Frangible or break-away base & hardware if required
- Footing materials if required
- If power is run on outside of pole (*as is typically done when installing to existing poles, or in the case of direct burial of pole*), 2 lengths of ½" conduit suitable for application (*recommended IMC or Rigid*)
- Sign strapping and strap installation tool (*see chart on following pages for strap size recommendations*) or heavy-duty tamper proof band clamps; U-bolts cannot be used with pole mounted battery box or SpeedCheck solar racks.

Overall pole length is not given, as it will vary depending upon footing, frangible base use, etc. Additional pole-mounted signage or devices may require higher and stronger poles. Select pole length to achieve minimum height above ground as shown in the drawing.

**Solar Powered**

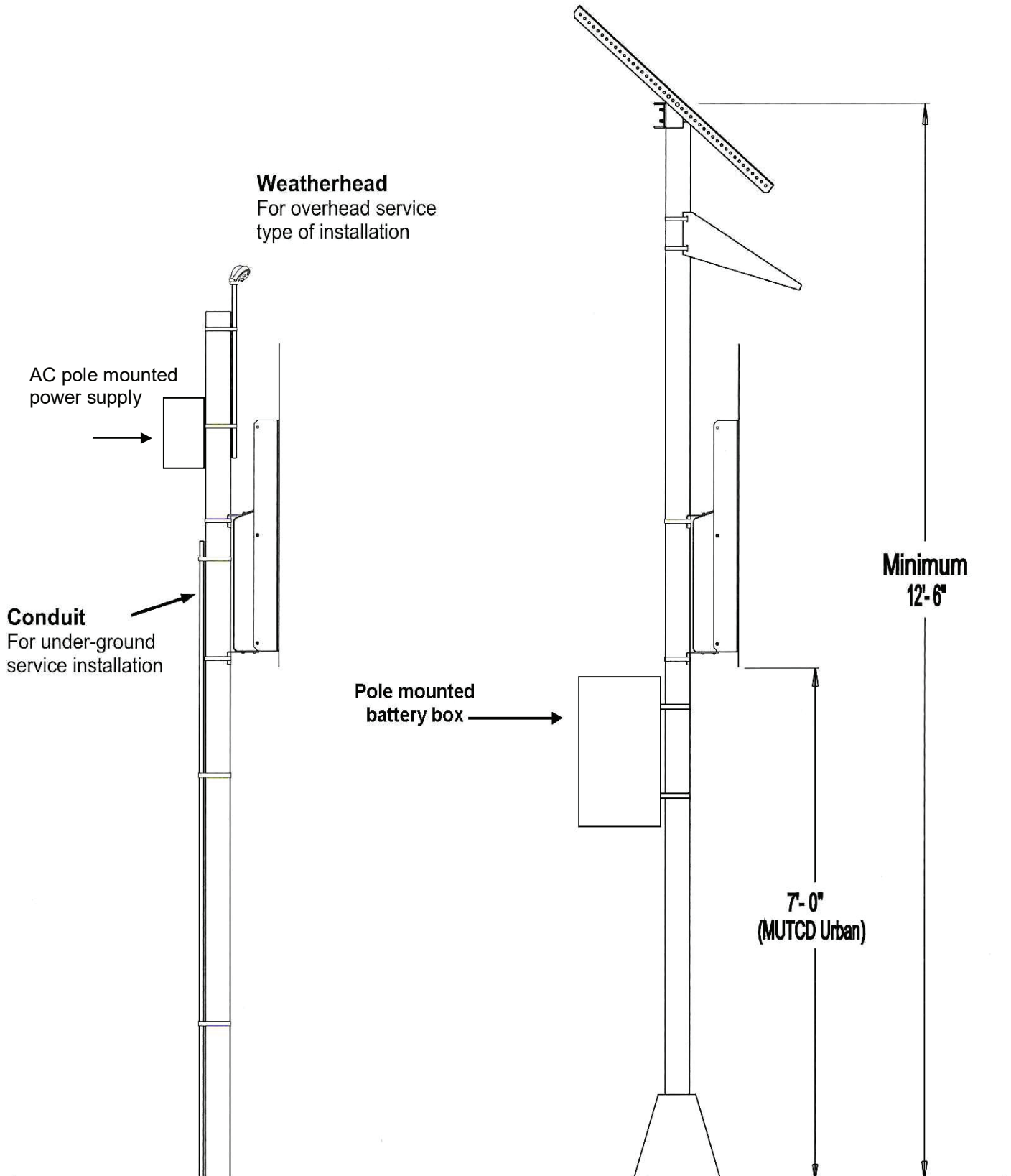

The following photos illustrate the assembly of the display to the pole. The brackets are best when attached to the pole using standard stainless steel sign strapping equipment. The chart on the following page lists the strapping requirements.

Hose clamps are ideal for initial temporary installation. They allow easy alignments and adjustment of the various components. Do not use hose clamps for permanent installation.



Strapping provides the most secure and vandal resistant mounting. If you don't have strapping equipment available, U-bolts can be used.

## **Strapping size recommendations**

### **For**

### **VSC-1820F and VSC-1520F displays**

#### **90 MPH wind loading**

#### ***3/4 x .030" band***

VSC-1520F Single wrap provides adequate strength for 90 MPH wind loading.

VSC-1820F Single wrap provides adequate strength for 90 MPH wind loading.

#### ***5/8 x .030" band***

VSC-1520F Single wrap provides adequate strength for 90 MPH wind loading.

VSC-1820F Single wrap provides adequate strength for 90 MPH wind loading, however double wrap is preferred on upper mounting bracket to prevent rotational slippage.

#### ***1/2 x .030" band***

VSC-1520F Single wrap provides adequate strength for 90 MPH wind loading, however double wrap is preferred on upper mounting bracket to preventing rotational slippage.

VSC-1820F Double wrap is required on upper mounting bracket.

### **Avoid These Common Installation Mistakes**

Installation immediately after a sharp curve – radar might not pickup approaching traffic, sign needs to be aimed correctly at approaching traffic

Installation on a steep incline or decline without using grade tilt brackets

Mounting a solar powered system in the shade of trees or large structures

Installing where large trucks may park and obscure the sign

Installation where the radar beam does not have a clear view of oncoming traffic because of obstructions, such as trees, foliage, signs, buildings, etc.

Installing the sign to far from the roadside. Typically, the SpeedCheck display is mounted between 5 feet and 12 feet from the roadside.



## Display Alignment

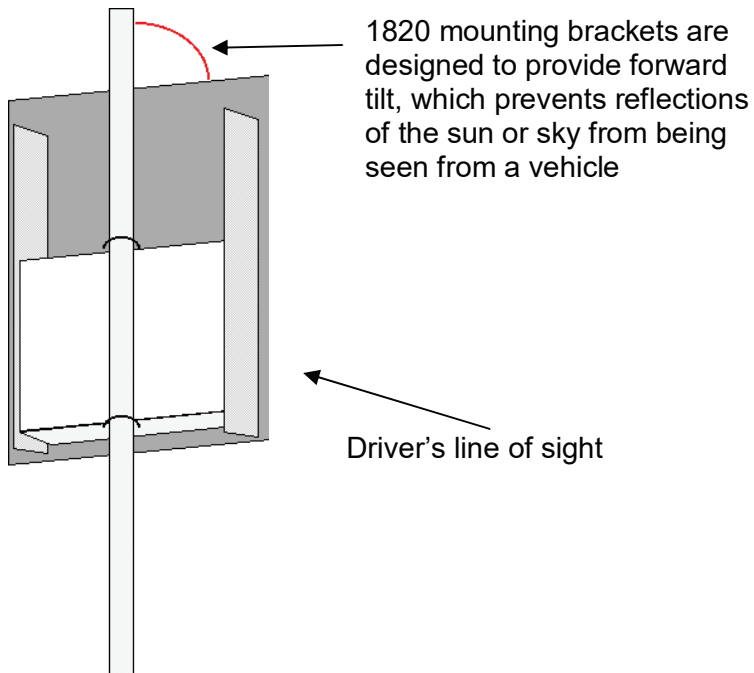

The 1820 series display systems are designed to overcome the conflict between maximization of the contrast of the display, and minimization of glare off the window. Specific design aspects of these systems dictate that, for these features to function properly, the display be aligned properly in relation to the roadway.

**Display alignment:** Direct the display into the roadway toward traffic as shown in the illustration, it should aimed at a point 200 ft. ahead of the sign.

**SpeedCheck displays are now all manufactured for universal mounting. A display may be mounted on the left, right, or in the median of a road, as long as the alignment procedure on page 8 is followed.**

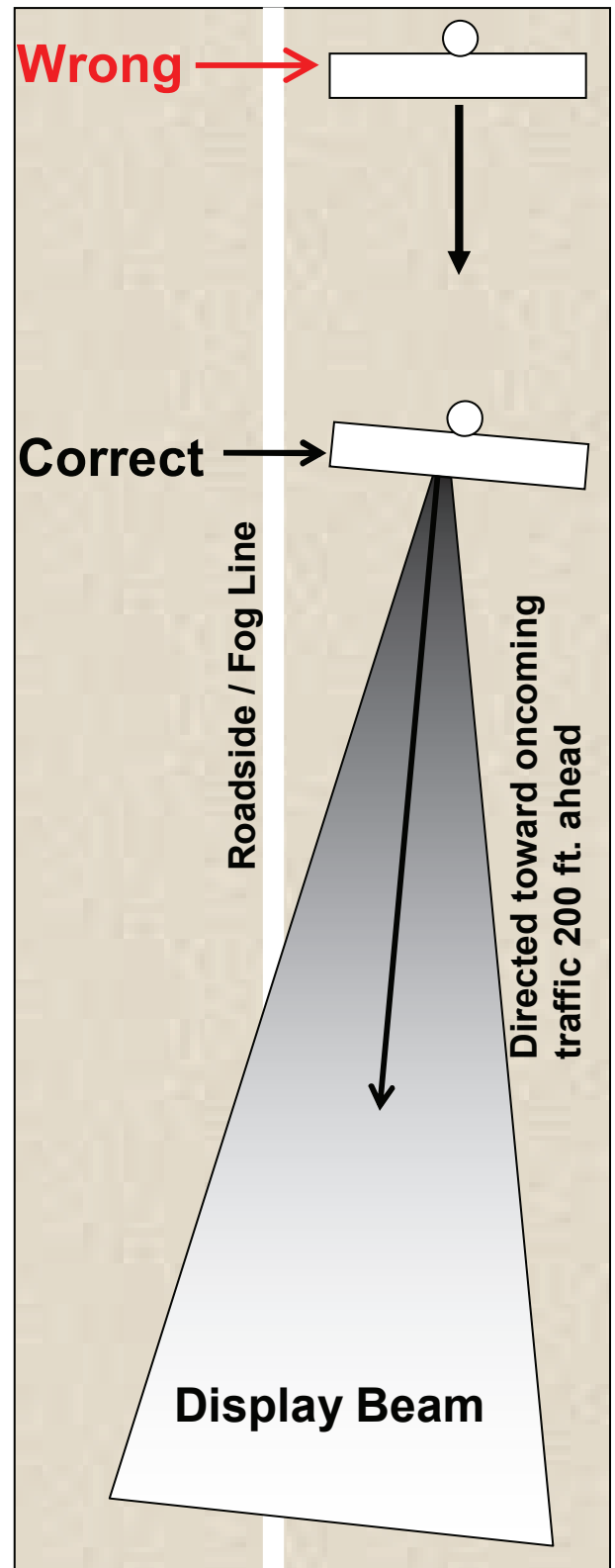

Left side of roadway  
sign mounting:

Right side of roadway  
sign mounting:

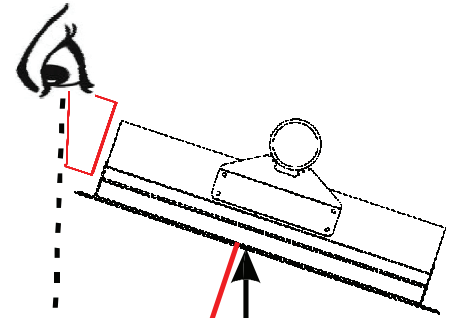
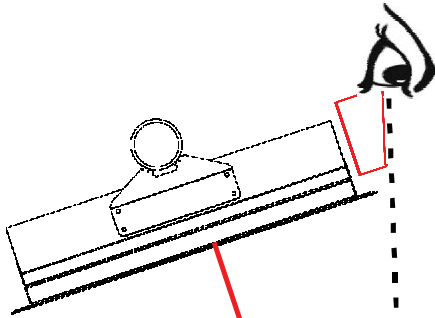

### Rotational sign alignment

1. Position the SpeedCheck sign at the correct height, and attach clamping devices loosely to allow rotation of the sign
2. Place the orange cone at the edge of the road (next to the fog line) 200 feet (about 80 paces) from the display, towards the direction of traffic.
3. Hold the aiming guide flange against the roadway side of the sign, with the narrow end of the guide to the front as shown.
4. Rotate the SpeedCheck display on the pole until the two points on the aiming guide visually lign up with the orange cone as shown here.
5. If done correctly, the sign face is now aimed at a point in the roadway approximately 200 feet from the sign and 12 feet in from the fog line as shown by the red line.
6. Tighten attachment devices.

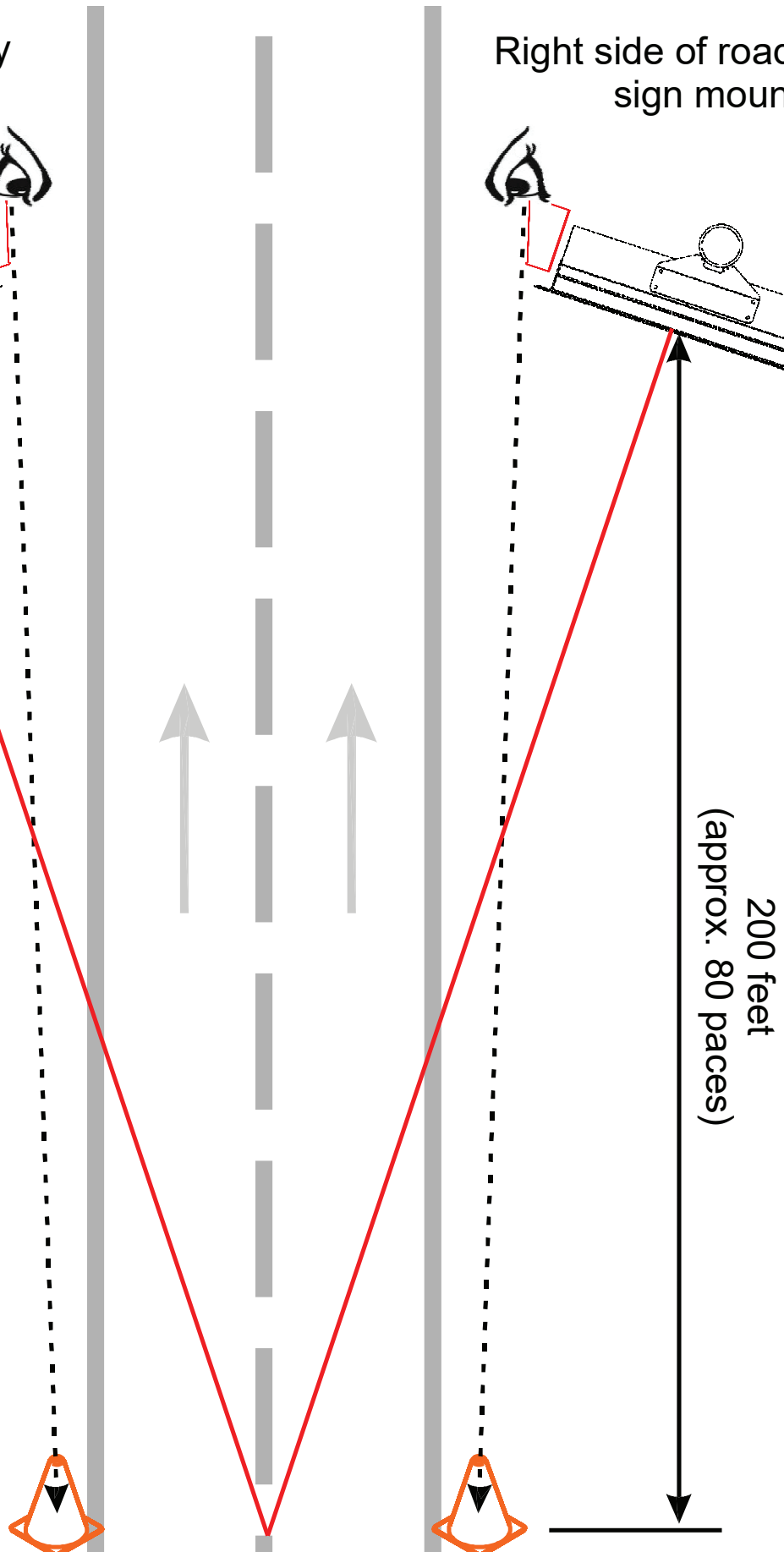

**Sky Reflections:** The 1820 display is designed to provide forward tilt, which prevents reflections of the sun or sky from being seen from a vehicle.

The display beam needs have clear view of oncoming traffic with no obstructions, such as trees, signs, buildings, etc. Additional consideration should be made for road curvature. If the display unit is displaying vehicle speed intermittently, the display may need to be turned slightly towards or away from the road to detect vehicles at the appropriate portion of the curve.

Typically, the SpeedCheck display is mounted between 5 feet and 12 feet from the roadside.

## Solar Panel Installation:

*When installing solar panel(s) always refer to manufacturer specifications for that particular panel(s), or feel free to call IDC Co. for technical assistance. Two panels should be wired in parallel – not in series. Use of a volt meter is always advised to determine proper terminal connection. Open solar panel circuit voltage should be between 17 – 22 volts.*

Typical Solar Power junction box connections are shown here. Black goes to the Negative (-) terminal, Red goes to the Positive (+) terminal. Use a volt meter to test panel output.



We find it easier to connect the power cable while the solar panel is still on the ground.

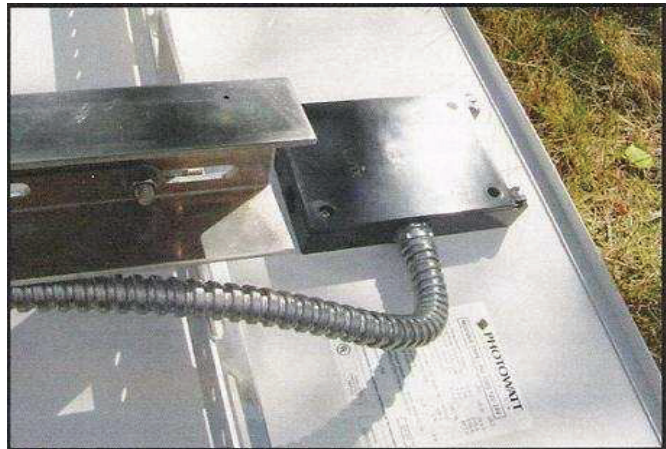

When attaching conduit to the junction box, use caution to put minimum amount of strain on the box. Most solar panel manufacturers consider a broken junction box un-repairable.

When wiring two solar panels together, the following web site is very useful:

<http://www.partsonsale.com/learnwiring.htm>

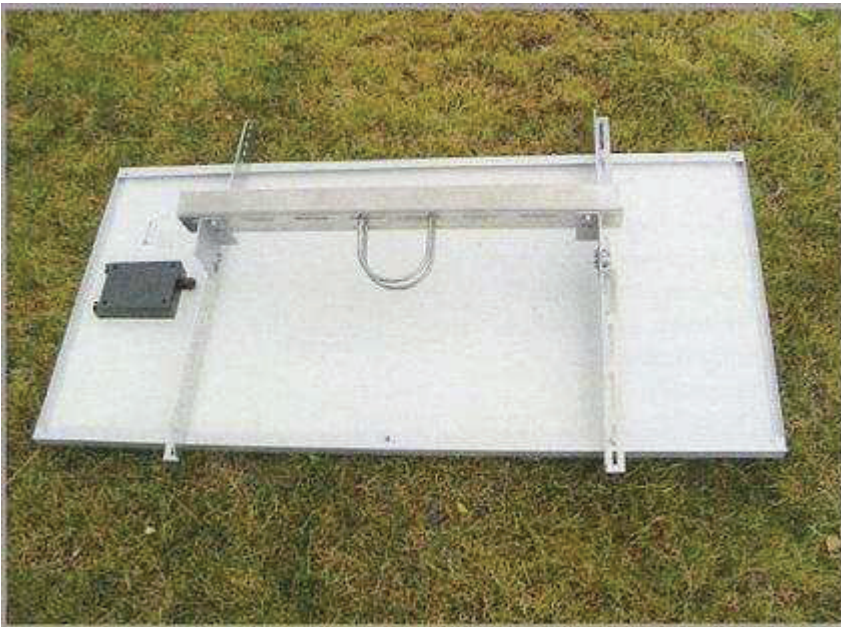

When a typical pole top mount is used, fully assemble the mounting bracket as shown in the assemble instructions that come with the bracket.

Adjust the mounting bracket to fit the solar panel mounting holes (do not mount to panel yet).

After the mounting bracket is assembled and properly set up for your specific solar panels, mount the bracket to the pole **without the solar panel(s)**.

Our experience has shown that it is easier to install the bracket first so that you can simply lay the solar panel atop the mounting bracket, and with the mounting bracket holding most of the weight of the solar panel, easily attach the mounting bolts to hold it in place. This is also safer, in that there is less chance of damaging the solar panel.



**NOTE! Make sure to connect the battery to the controller first before connecting the solar panel, or the controller will be damaged and will no longer be usable.**

1820 signs have an internal 4 amp fuse located in the backpanel. A 15 amp in-line fuse is in the cable from the battery to the solar controller.

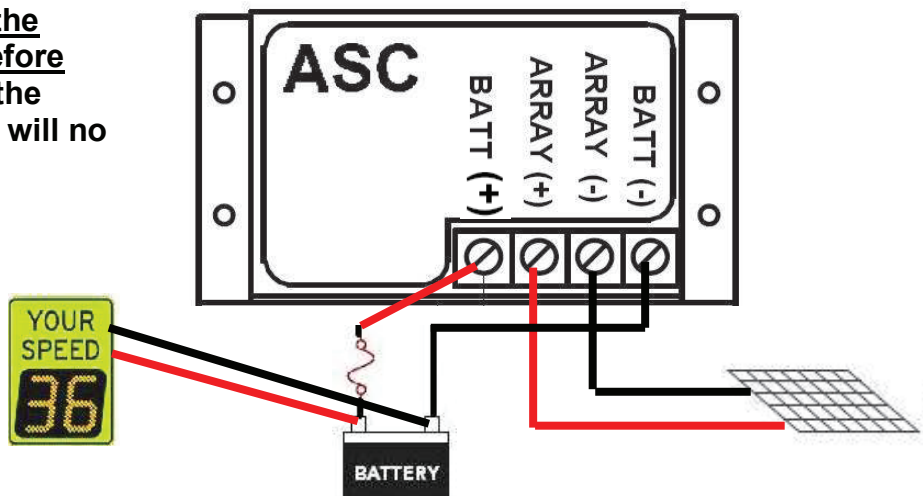

## Solar Panel Mounting Angle

Your Latitude	Angle From Horizontal	Rise / Run (A/B)
<b>60</b>	<b>77</b>	<b>4.33</b>
<b>55</b>	<b>72</b>	<b>3.08</b>
<b>50</b>	<b>67</b>	<b>2.36</b>
<b>45</b>	<b>62</b>	<b>1.88</b>
<b>40</b>	<b>57</b>	<b>1.54</b>
<b>35</b>	<b>52</b>	<b>1.28</b>
<b>30</b>	<b>47</b>	<b>1.07</b>
<b>25</b>	<b>42</b>	<b>0.90</b>
<b>20</b>	<b>37</b>	<b>0.75</b>

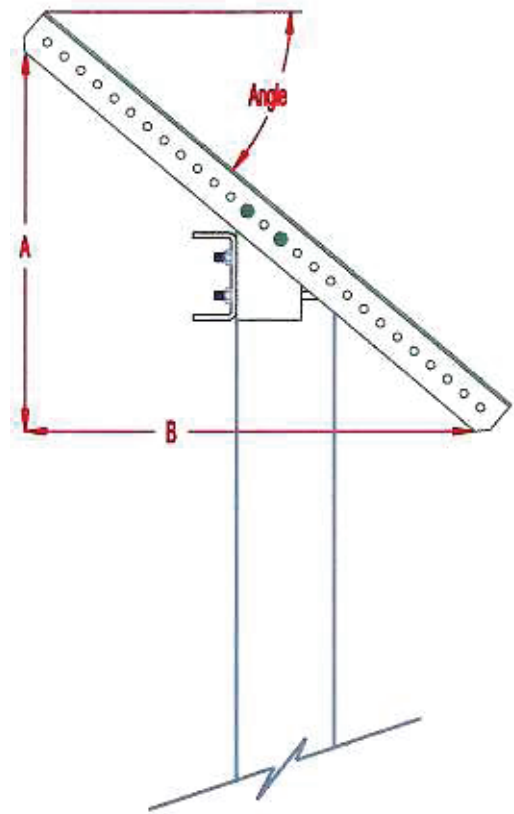

The solar panels supplied have been selected to provide adequate power to the system under the worst-case situation, which will typically be during the period of time following the winter solstice. The solar panels must be oriented for maximum efficiency at that time. It is also important to know the location and hours of operation the system was designed for. If a solar powered display is operated in a manner not compatible with the original design, then the solar power components may be overly stressed or damaged, thus negating the manufactures warranty.

The mounting bracket allows the panel to be tilted towards the sun at the appropriate angle. Determine the correct angle for your location using the table above, and adjust the bracket to the approximate angle shown (accuracy within 5 degrees is close enough... 5 degrees of tilt away from the perfect orientation will cause a loss in efficiency of only about 0.4%).

Locate the panel rotationally on the pole so that it is directed due south.



These upper photos show an installation where the power cables are run inside the pole. The display conduit is run up to the top of the pole and down the inside.

In areas that are well away from the reach of pedestrians, all stainless steel hose clamps are a simple, quick, and reliable way to attach the conduit to the pole and brackets.

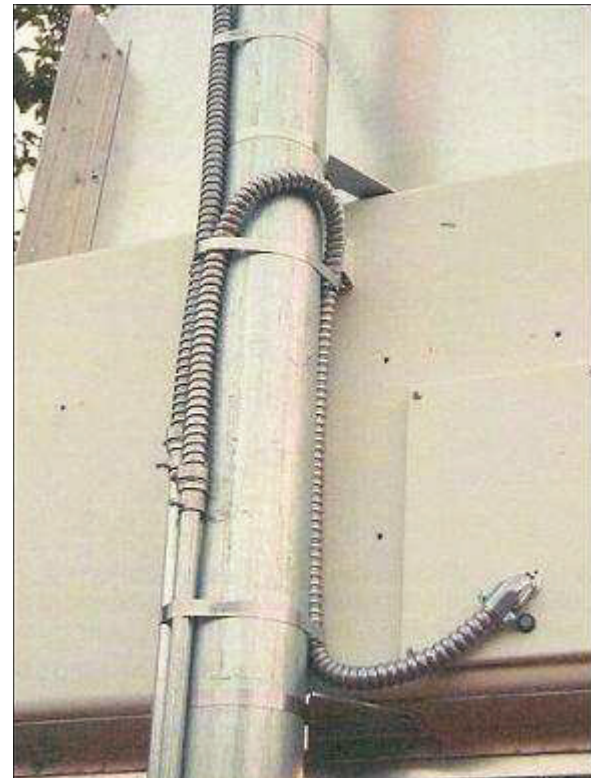

On existing poles, or new installations of buried poles, external conduit strapped to the outside of the pole is the easiest method to route wiring.

## 1820 Standard Board Display Cable Connections

**Connect the display cables before connecting the power cable.**

The **3 pin & 7 pin (2 & 3)** connectors go the **Right** LED display.

The **5 pin & 7 pin (1 & 4)** connector go to the **Left** LED display.

Right LED Display

Left LED Display

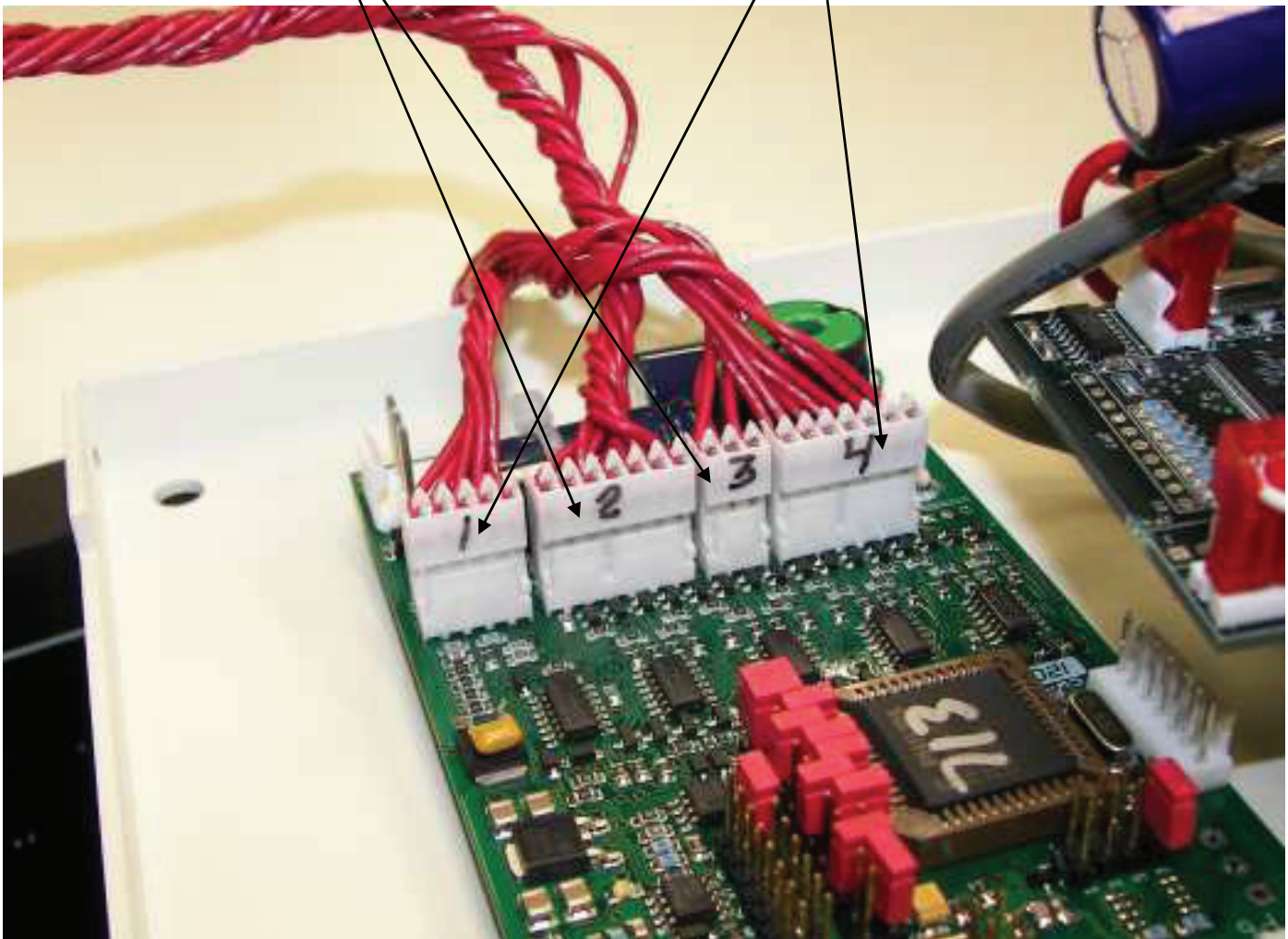

## 1820 Programmable Display Cable Connections

**Connect the display cables before connecting the power cable.**

The **3 pin & 7 pin (2 & 3)** connectors go to the **Right** LED display.

The **5 pin & 7 pin (1 & 4)** connector go to the **Left** LED display.

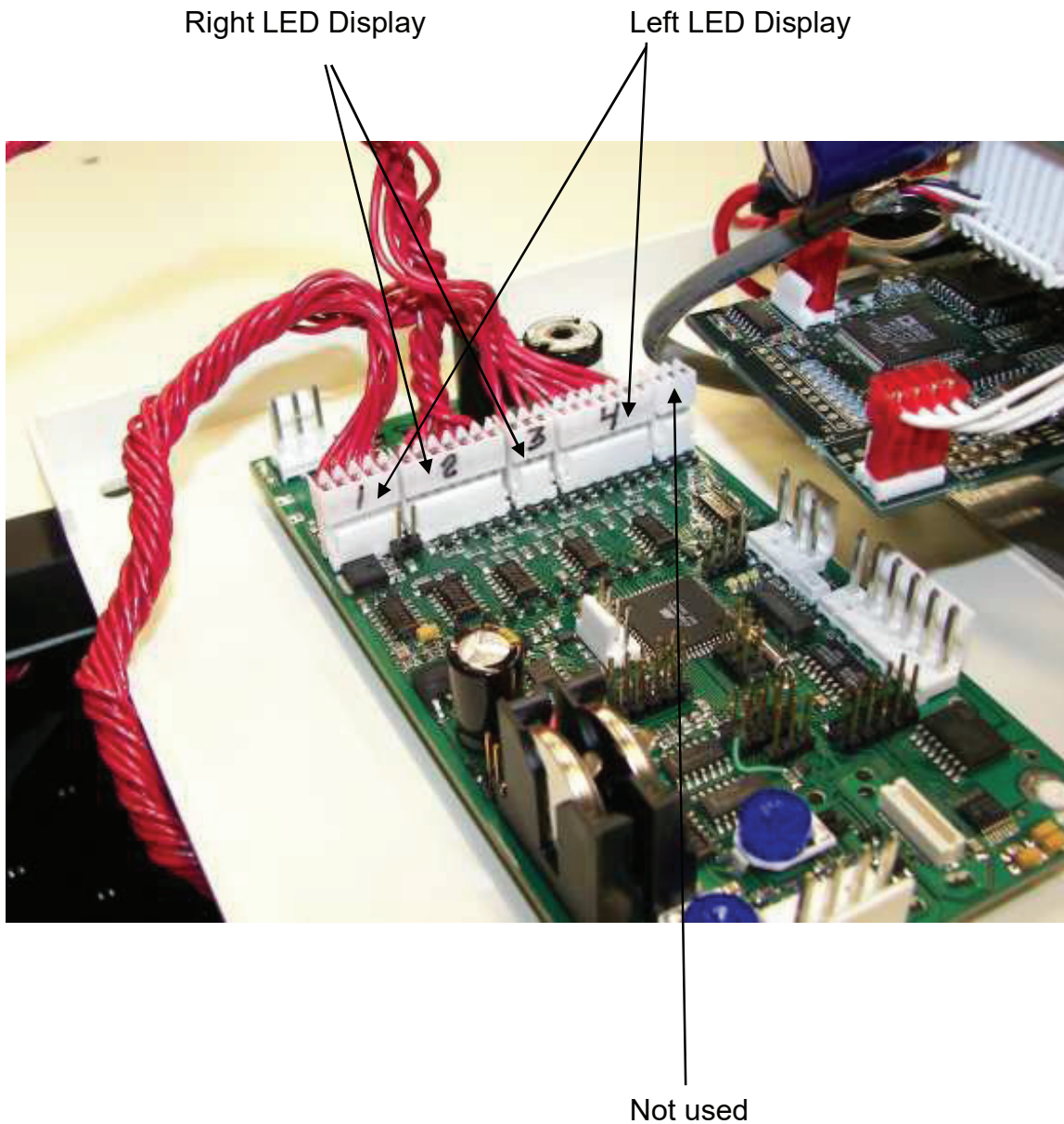



## Customer Service and Warranty

This product is covered by a limited warranty for the product excluding batteries, and a separate limited warranty for the batteries.

Visit [www.carmanahtraffic.com](http://www.carmanahtraffic.com) for additional information or contact the customer service department.

Before contacting Carmanah's customer service department, please have the serial number of your system available, a brief description of the problem, as well as all details of the installation (location, pole type, type and quantity of fixtures, etc.)

To contact Carmanah's customer service department:

**Mail:** Carmanah Technologies Corporation  
250 Bay Street  
Victoria, BC V9A 3K5, Canada

**Phone:** 1.250.380.0052  
1.877.722.8877 (Toll Free in U.S. and Canada)

**Fax:** 1.250.380.0062

**Email:** [customersupport@carmanah.com](mailto:customersupport@carmanah.com)

**Website:** [carmanahtraffic.com](http://carmanahtraffic.com)