

SC315-G

Cabinet-Based Rectangular Rapid Flashing Beacon Data Sheet



Rectangular rapid flashing beacons (RRFBs) improve pedestrian safety by increasing yield rates to 72-96% at crosswalks*:

- ✓ The benchmark for RRFBs, the SC315-G meets MUTCD requirements, including IA-21, and is Buy America compliant
- ✓ Audible pushbutton or passive pedestrian activation
- ✓ Solar or AC-powered
- ✓ Solar Power Report™ (SPR) prepared for every location to ensure battery longevity

Superior Design and Technology

The SC315-G is a cabinet-based system with a separate, high-power solar panel. This design enables the SC315-G to work with audible pushbutton stations, passive activation sensors, and remote monitoring, as well as operate at higher intensities and increased activations in challenging environments. MUTCD interim approval IA-21 flash pattern and multiple configurations enable the SC315-G to handle all crosswalk applications.

Easy Installation

All components, including the battery or AC power supply, Energy Management System (EMS) and optional audible pushbutton controller are housed in a compact, lockable, purpose-built enclosure. It also incorporates a wire routing and termination system, and all components are wired at the factory for an efficient installation.

Advanced User Interface

The SC315-G comes with an on-board user interface for quick configuration and status monitoring. It allows for simple in-the-field adjustment of flash pattern, duration, intensity, ambient auto adjust, night dimming, and many more. Settings are automatically sent wirelessly to all units in the system.

Reliable

Every solar-powered model is solar-sized by location to ensure year-after-year operation. Carmanah includes a Solar Power Report to prove sustainability over a 12-month period.



MUTCD
compliant



Buy America
compliant



5-year limited
warranty



Solar-sized for
every location

* U.S. Department of Transportation Federal Highways Administration, Publication No. FHWA-HRT-10-043 - "Effects of Yellow Rectangular Rapid-Flashing Beacons on Yielding at Multilane Uncontrolled Crosswalks"

SC315-G

Cabinet-Based Rectangular Rapid Flashing Beacon Data Sheet

1.844.412.8395 | traffic@carmanah.com | carmanah.com



CABINET DIMENSIONS

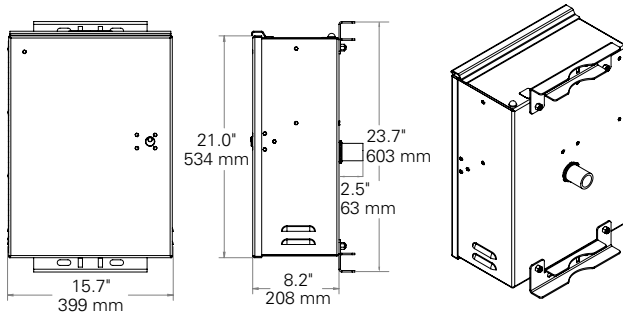

SOLAR PANELS AND MOUNTS

3.5" - 4.5" Diameter Round Top of Pole Mount

Side of Pole Mount

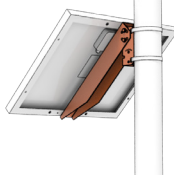
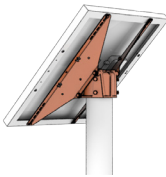

PANEL*	LENGTH	WIDTH
20 W**	18.5" (470 mm)	13.6" (345 mm)
50 W	26.3" (668 mm)	21.2" (538 mm)
80 W	30.7" (780 mm)	26.5" (672 mm)

* Carmanah will conduct a site assessment and provide an Solar Power Report to determine the correct solar panel and battery size.

** Only available in a Side of Pole configuration.

LIGHT BAR CONFIGURATION

Uni-directional Configuration

Bi-directional Configuration

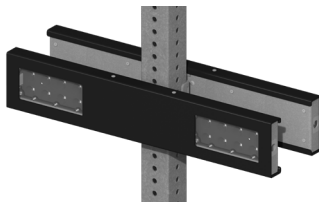
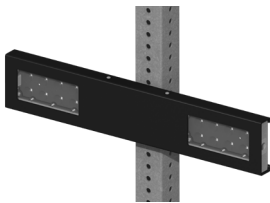

ACTIVATION OPTIONS

Standard Pushbutton

Audible Pushbutton Station

Passive Activation Sensor

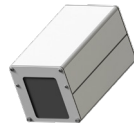

BEACON SPECIFICATIONS

Optical	MUTCD interim approval IA-21 and MUTCDC compliant
	Purpose-built light bar optics = maximum efficiency and no stray light Exceeds SAE J595 class 1 intensity by 2.5 to 3x when used as recommended Meets SAE J578 chromaticity
	3 in (76 mm) x 7 in (178 mm) clear, UV-rated polycarbonate lens with yellow LEDs
	High-power LEDs: +90% lumen maintenance (L90) based on IES LM-80
	Side-emitting pedestrian confirmation LEDs
	Independent, stainless steel mounting brackets make back-to-back installation simple and enable in-field aiming for maximum effectiveness
	Yellow, black, or green powder coated light bar covers

SYSTEM SPECIFICATIONS

On-Board User Interface (OBUi)	Adjustable system settings with auto-scrolling LED display on our latest EMS
	System test, status, and fault detection: battery, solar, button, beacon, radio, day/night
	Flash patterns: RFB (WW+S), RFB1 (WW+S legacy), RFB2 (WSDOT), 0.5 sec. alternating (MUTCD), 0.5 sec. unison (MUTCD), 0.5 sec. x3 alternating (MUTCD), 0.1 sec. unison, 0.25 sec. unison, 0.1 sec. x3 quick flashes unison, 0.1 sec. x3 quick flashes alternating, steady on
	Input: momentary for pushbutton activation, normally open switch, normally closed switch, dusk-to-dawn operation
	Flash duration: 5 sec. to 1 hr.
	Intensity setting: 20 to 1400 mA for multiple RFBs, circular beacons, or LED enhanced signs
	Nighttime dimming: 10 to 100% of daytime intensity
	Ambient Auto Adjust: increases intensity during bright daytime
	Automatic Light Control: reduces intensity if the battery is extremely low
	Temperature correction: yellow beacons
Beacon Communication	Calendar: internal time clock function
	Radio settings: enable/disable, selectable channel from 1 to 14
	Output: enabled when beacons flashing daytime and nighttime, or nighttime only E.g., for relay control of overhead lighting
	Activation counts and data reporting via OBUi or optional USB connection
	Encrypted, wireless radio with 2.4 GHz mesh technology
	Wireless update of settings from any unit to all systems on the same radio channel
	User-selectable multiple channels to group different beacons and ensure a robust wireless signal
	Communicates with all other Gen III radio-enabled systems including our R820-E, -F, and -G circular beacons
	Instantaneous wireless activation: <150 ms
	Wireless range: 1000 ft (305 m)
Power System	Integrated, vandal-resistant antenna
	Solar or AC-powered
	AC: 100-240 VAC input, 6-14 AWG Replaceable AC-DC power supply, circuit breaker, terminal block wiring
Energy Collection	20, 50, or 80 W high-efficiency photovoltaic solar panel
	45 deg tilt for optimal energy collection Maximum Power Point Tracking with Temperature Compensation (MPPT-TC) battery charger for optimal energy collection in all solar and battery conditions
Energy Storage	12 V battery system with multiple sizes: 35, 55, 100 Ahr.
	Replaceable, recyclable, sealed, maintenance-free, best-in-class AGM batteries offer the widest temperature range and longest life Battery design life: +5 yrs.
Cabinet Construction	Weatherproof, gasketed enclosure with vents for ambient air transfer (NEMA 3R)
	Lockable, hinged door with #2 lock Optional padlockable latch
	Corrosion-resistant aluminum with stainless steel hardware
	Raw aluminum finish or yellow, black, or green powder coated
	Prewired to minimize installation time
Environmental	High-efficiency optics and EMS = the most compact, lightweight system
	-35 to 165° F (-37 to 74° C) system operating temperature
	-40 to 140° F (-40 to 60° C) battery operating temperature 150 mph (241 kph) wind speed as per AASHTO LTS-6
Activation	Pushbutton: ADA-compliant, piezo-driven with visual LED and two-tone audible confirmation
	Audible pushbutton station: ADA-compliant, piezo-driven with visual LED and customizable voice message confirmation
	Passive activation: microwave-based sensor detects pedestrian
Warranty	5-year limited warranty, 1-year limited on batteries
Customize	Build an RRFb online

Specifications subject to local environmental conditions, and may be subject to change.

All Carmanah products are manufactured in facilities that are certified to ISO quality standards.

"Carmanah" and Carmanah logo are trademarks of Carmanah Technologies Corp.

© 2022, Carmanah Technologies Corp.

Document: Carmanah_DATA_SC315-G_RevC