



Warnings and Precautions

The following symbols indicate important safety warnings and precautions throughout this manual. They are defined as follows:



WARNING indicates that serious bodily harm or death may result from failure to adhere to the precautions.



CAUTION indicates that damage to equipment may result if the instructions are not followed.



NOTE suggests optimal conditions under which the equipment will operate effectively and safely, or provides additional information to the reader.

Warranty Disclaimer

This manual will familiarize you with the features, operation standards, and installation of Carmanah's SC315 Rectangular Rapid Flasher Beacon series. Failure to comply with the use, storage, maintenance, installation or placement instructions detailed in this manual could void the warranty.

Standards

Perform all installation, wiring and maintenance in conformance with local building and electrical codes. Adherence to the National Electrical Code (NEC) is mandatory to comply with any certification markings. Non-adherence to code may void the warranty.

Safety and Usage Precautions



Before lifting any heavy or bulky equipment, ensure that the load is secured so that moving parts do not shift and it can be lifted as far as needed without back strain or loss of grip. Installation may require more than one person.

Ensure the equipment is not powered during installation and wiring of the system.

Re-check all completed wiring for proper polarity prior to energizing the system.



Changes or modifications to Carmanah equipment not expressly approved by Carmanah could void the user's authority to operate the equipment.

Introduction

SC315 series LED Rectangular Rapid Flashing Beacon products are ideal for pedestrian activated crosswalk applications.

System Components

The SC315 series can be configured to meet a variety of crosswalk requirements. The following components make up each of these configurations:

- Control Cabinet, consisting of:
 - Energy Management System (EMS)
 - Connection Bar
- Flashing LED Light Bar(s)
- Universal Light Bar Bracket(s)
- Pedestrian Push Button(s)

The EMS controls the Flashing LED Light Bar(s), responds to push button signals, and communicates to other systems in the crosswalk set.

System Configurations

The SC315 series configurations are combined to create a complete crosswalk set. Each SC315 in the set is radio controlled, and synchronizes with the other units in the set.

Pedestrian Confirmation LED Options

Single light bar, no confirmation light



Single light bar, dual confirmation light

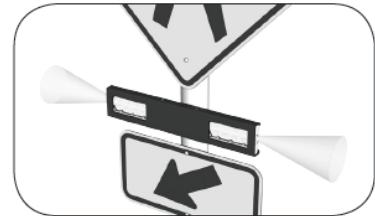

Dual light bar, no confirmation light

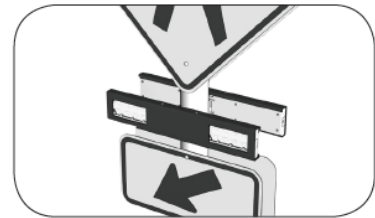

Dual light bar, dual confirmation light

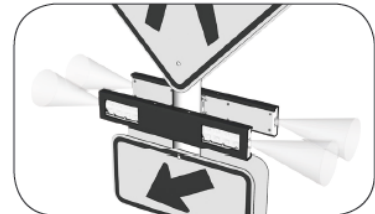

Note: Confirmation lights may be blocked on either end by using supplied opaque labels during installation.

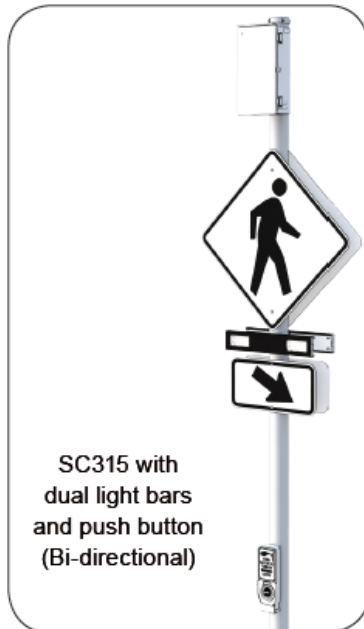
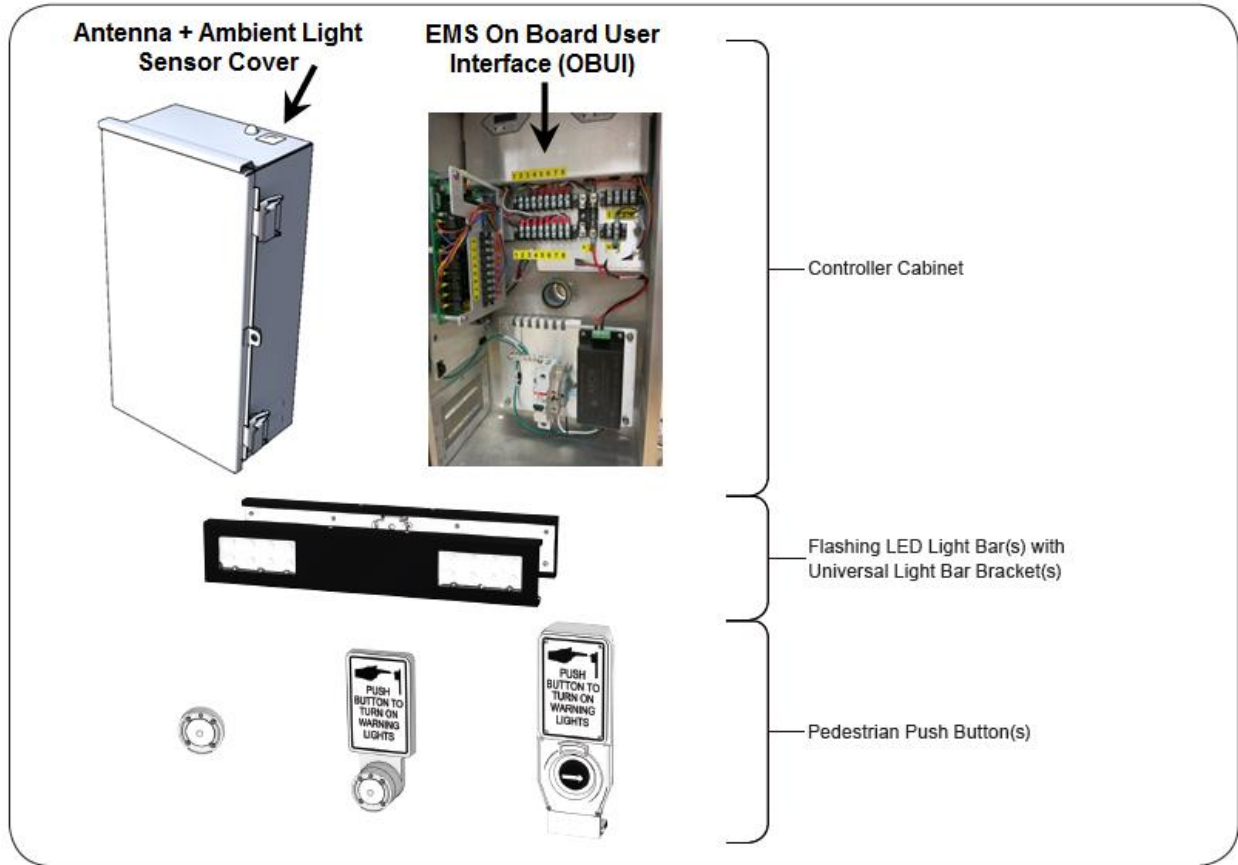

Typical Installations

Standard - Two-way Roadway

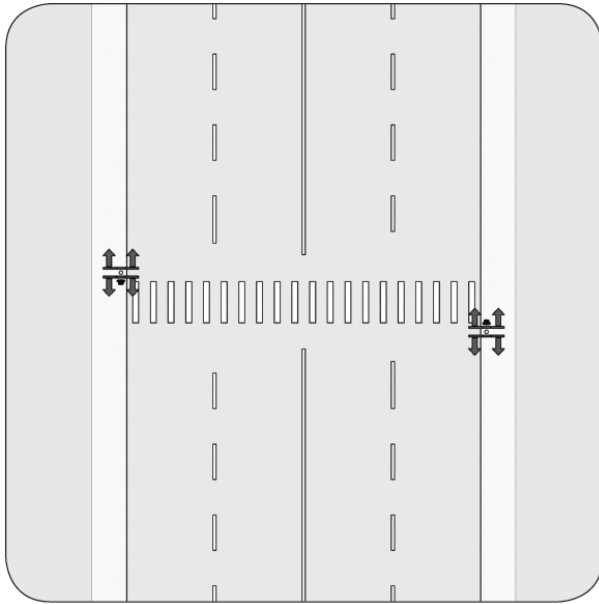

Advance - Two-way Roadway

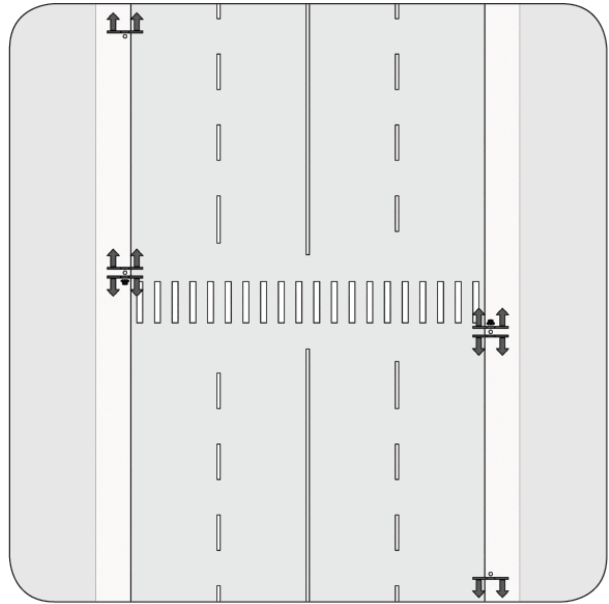

Standard - One-way Roadway

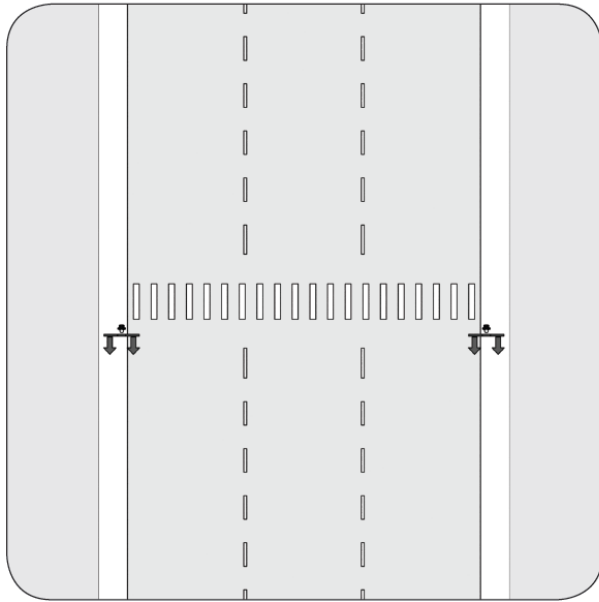

Single Pole Median - Two-way Roadway

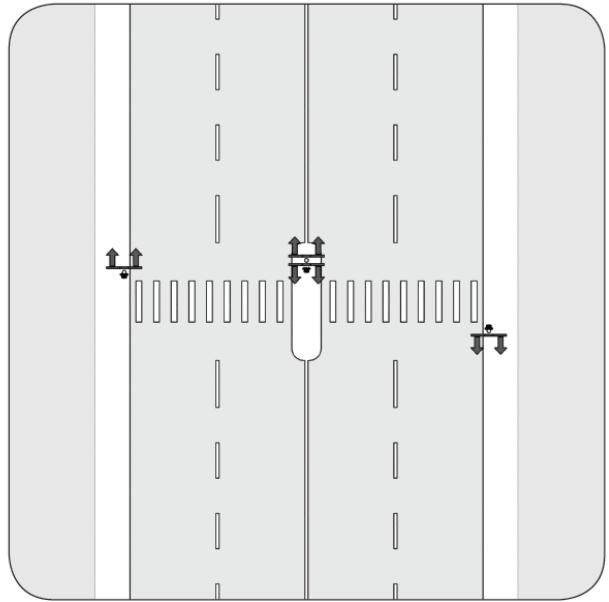

Two Pole Median - Two-way Roadway

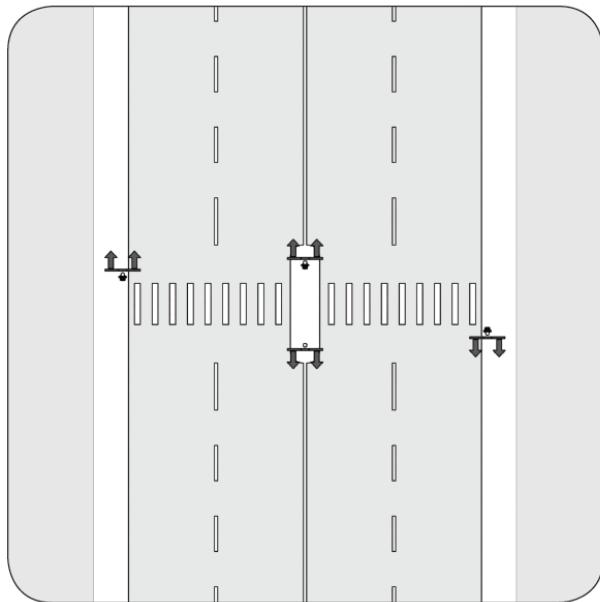

Overhead - Two-way Roadway

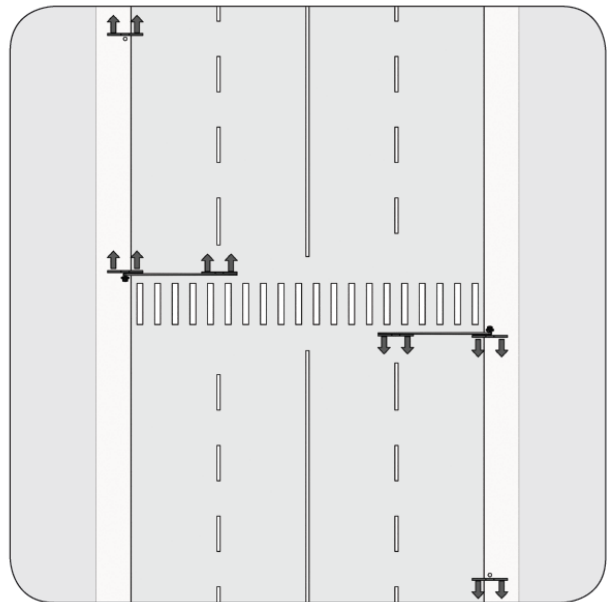

Roundabout

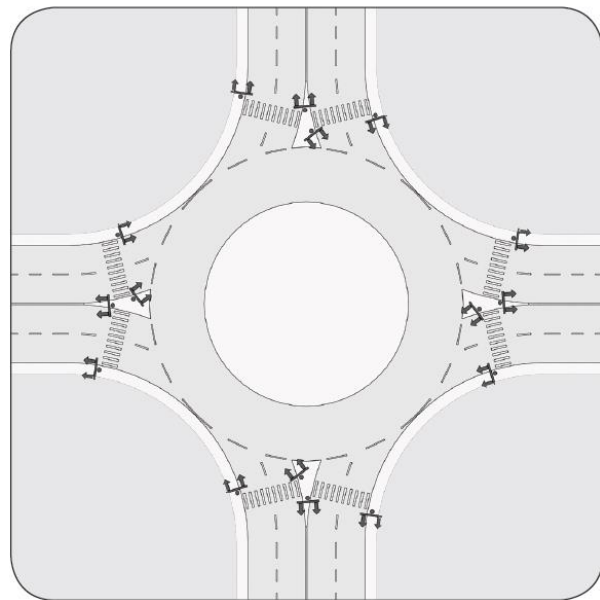

Four Pole - Parallel Crosswalks

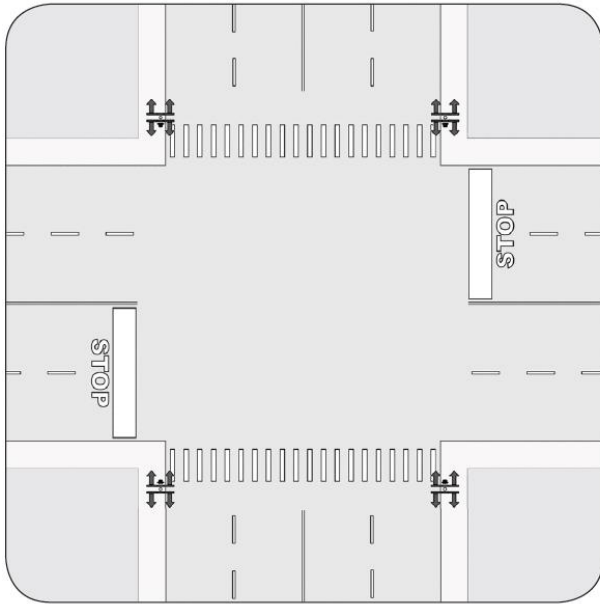

Two Pole, Staggard - Parallel Crosswalks

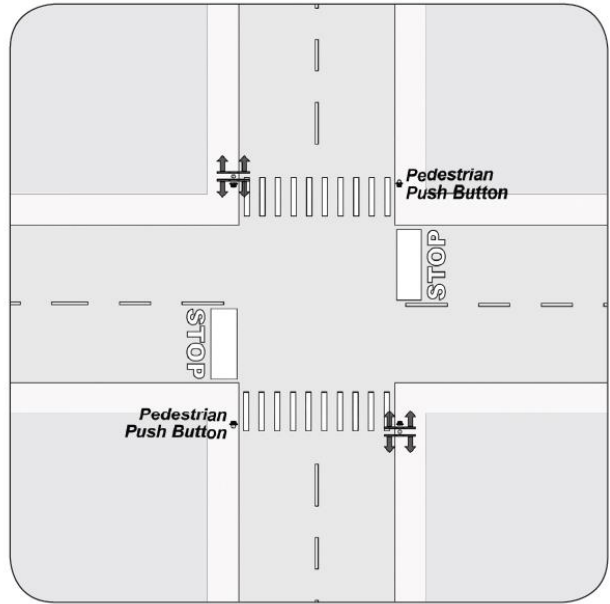

Four Pole with Median - Parallel Crosswalks

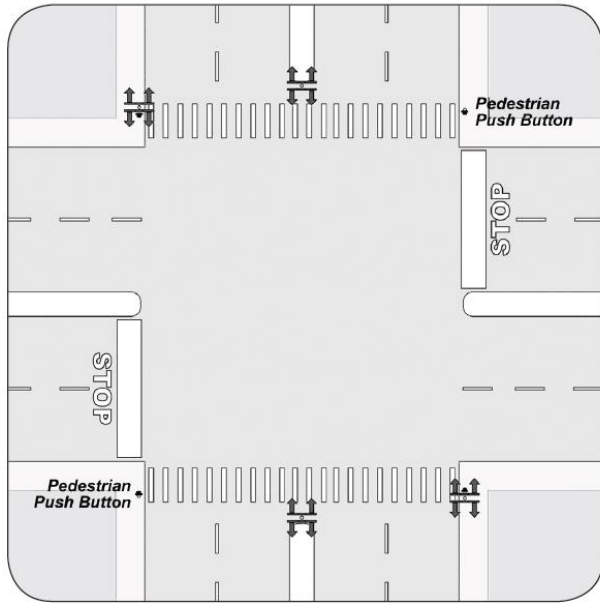

Typical Pole and Sign Configuration

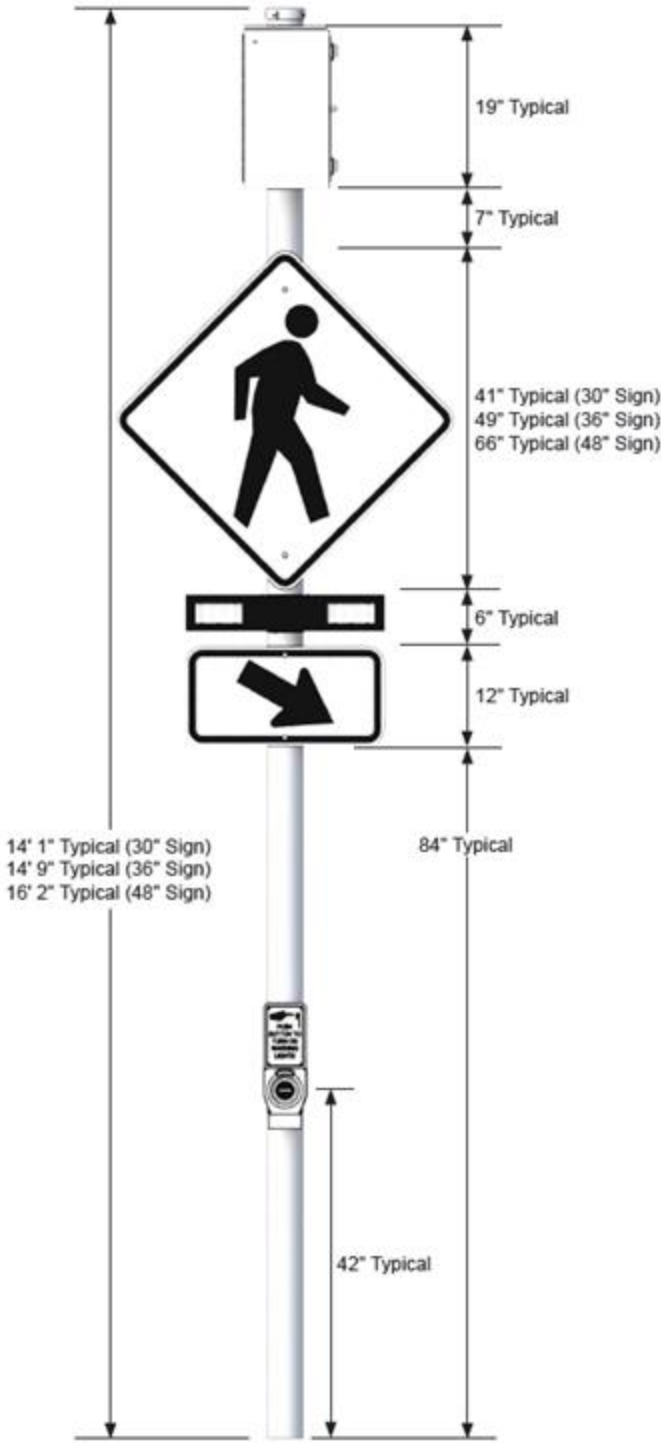

System Wiring Connections:

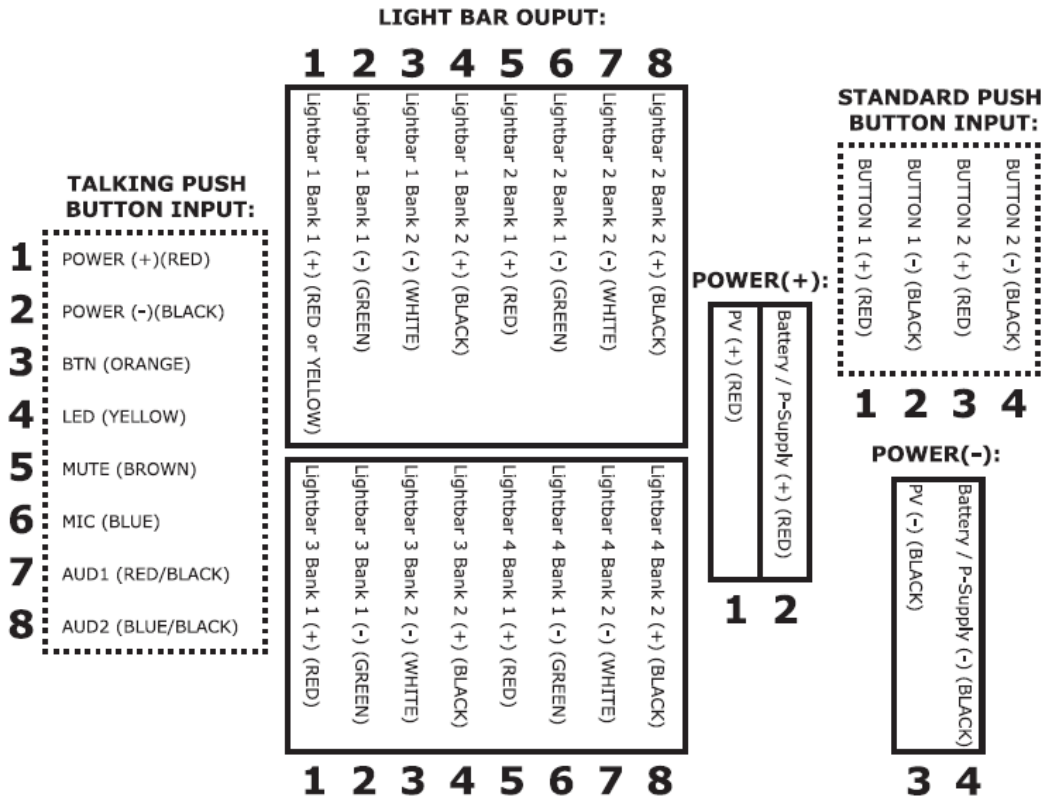

NOTE:

- Dashed Lines indicate either standard or talking push button inputs are to be used.
- Light bar bank 1 (+) uses a yellow wire for the talking push button version.
- PV (+) is not used for the AC version of the system.

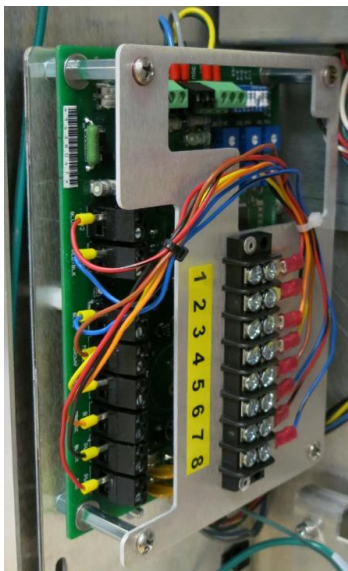

TALKING PUSH BUTTON PCB

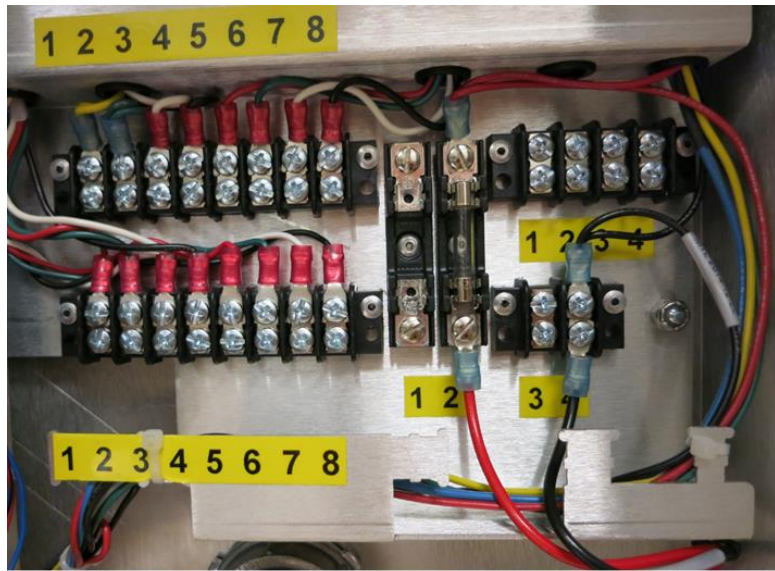

MAIN CONTROL PANEL

Wiring Layout:

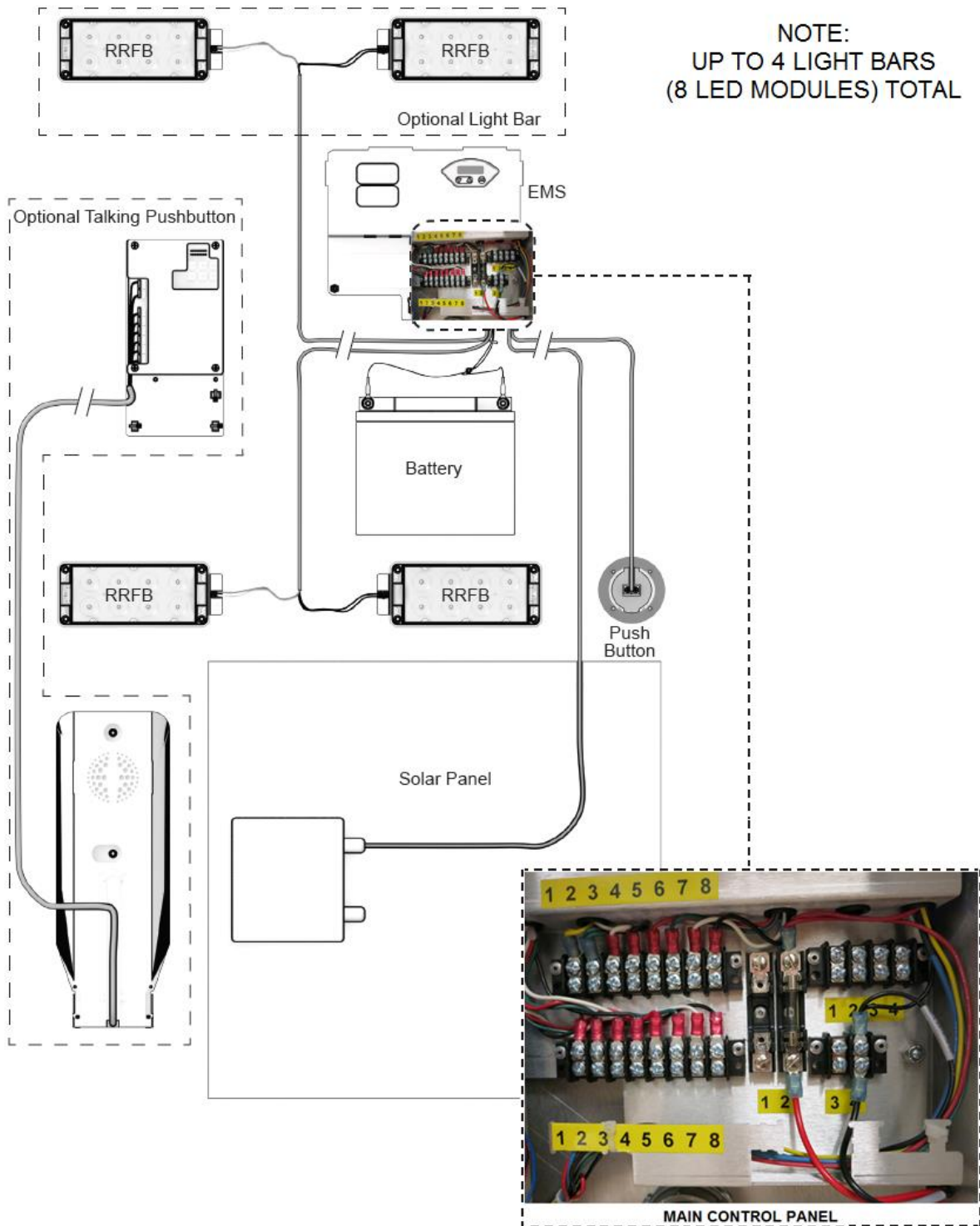

System Configurations

SC315-AC – Single Controller (1-2 Light Bars, Standard Push Button):

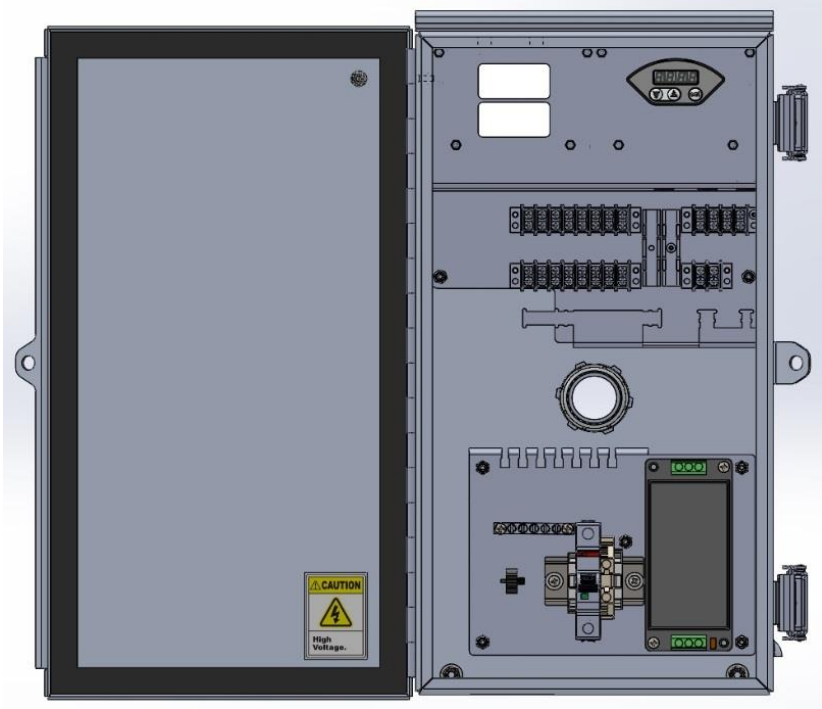

SC315-AC – Dual Controller (3-4 Light Bars, Standard Push Button):

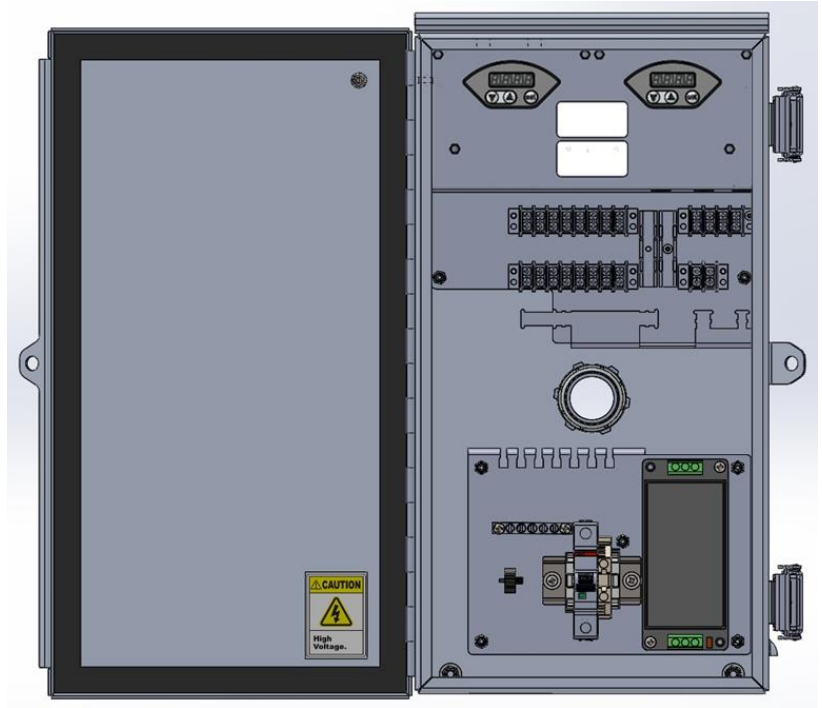

SC315-AC – Single Controller (1-2 Light Bars, Talking Push Button):

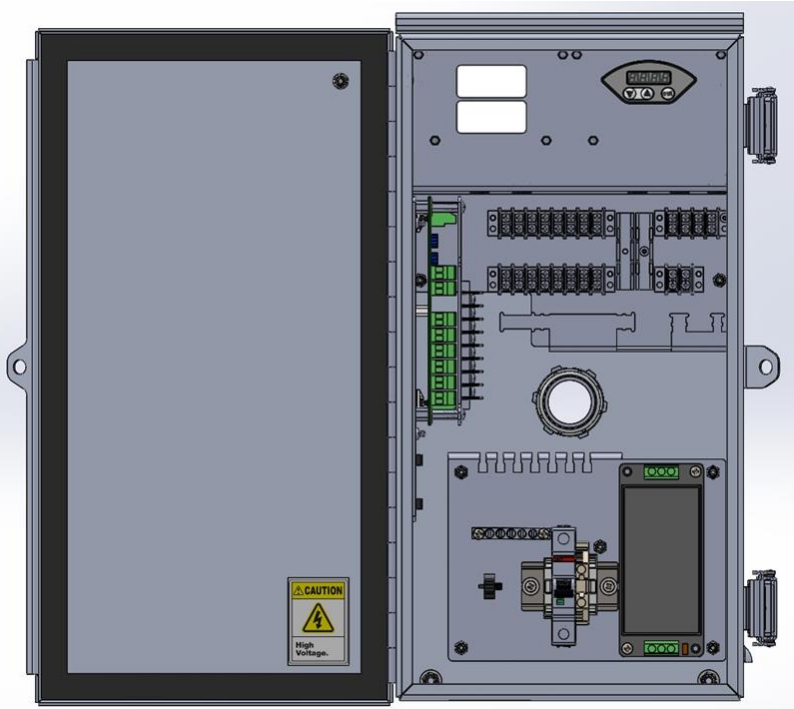

SC315-AC – Dual Controller (3-4 Light Bars, Talking Push Button):

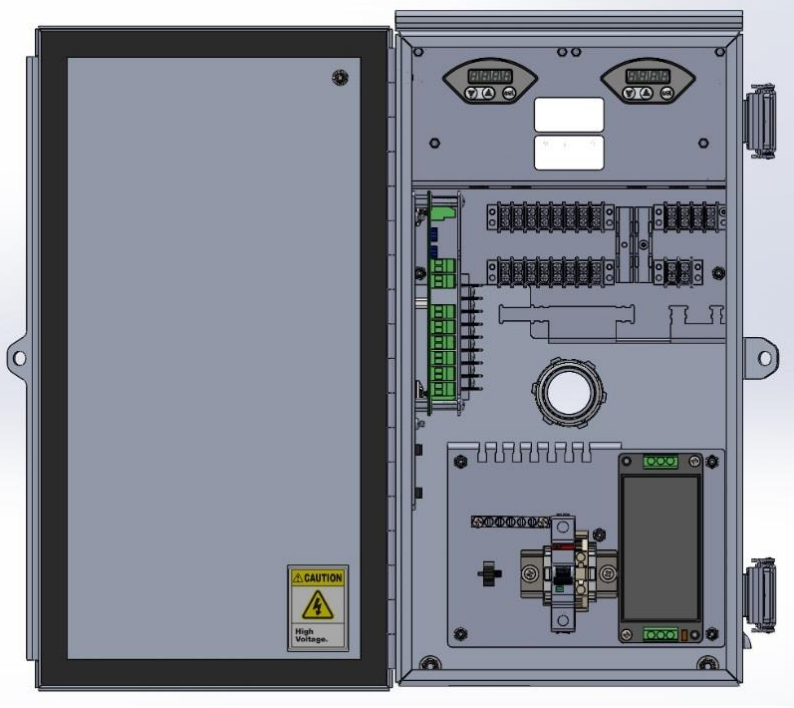

SC315 - AC POWER, 1/2 LIGHTBARS, PUSH

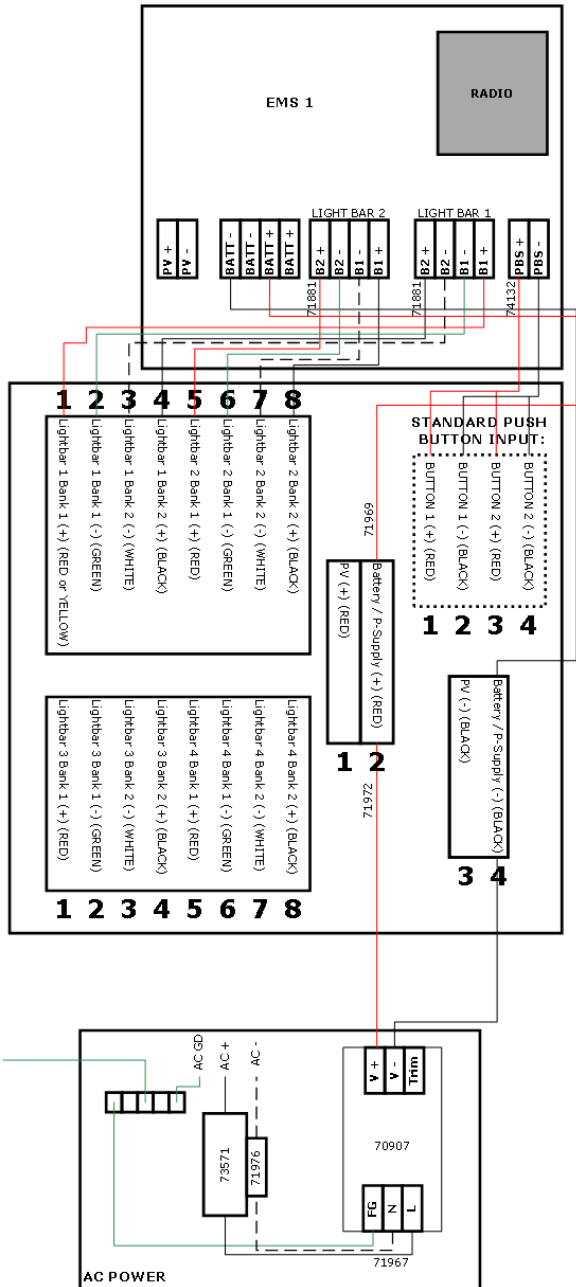

SC315 - AC POWER, 3/4 LIGHTBARS, PUSH

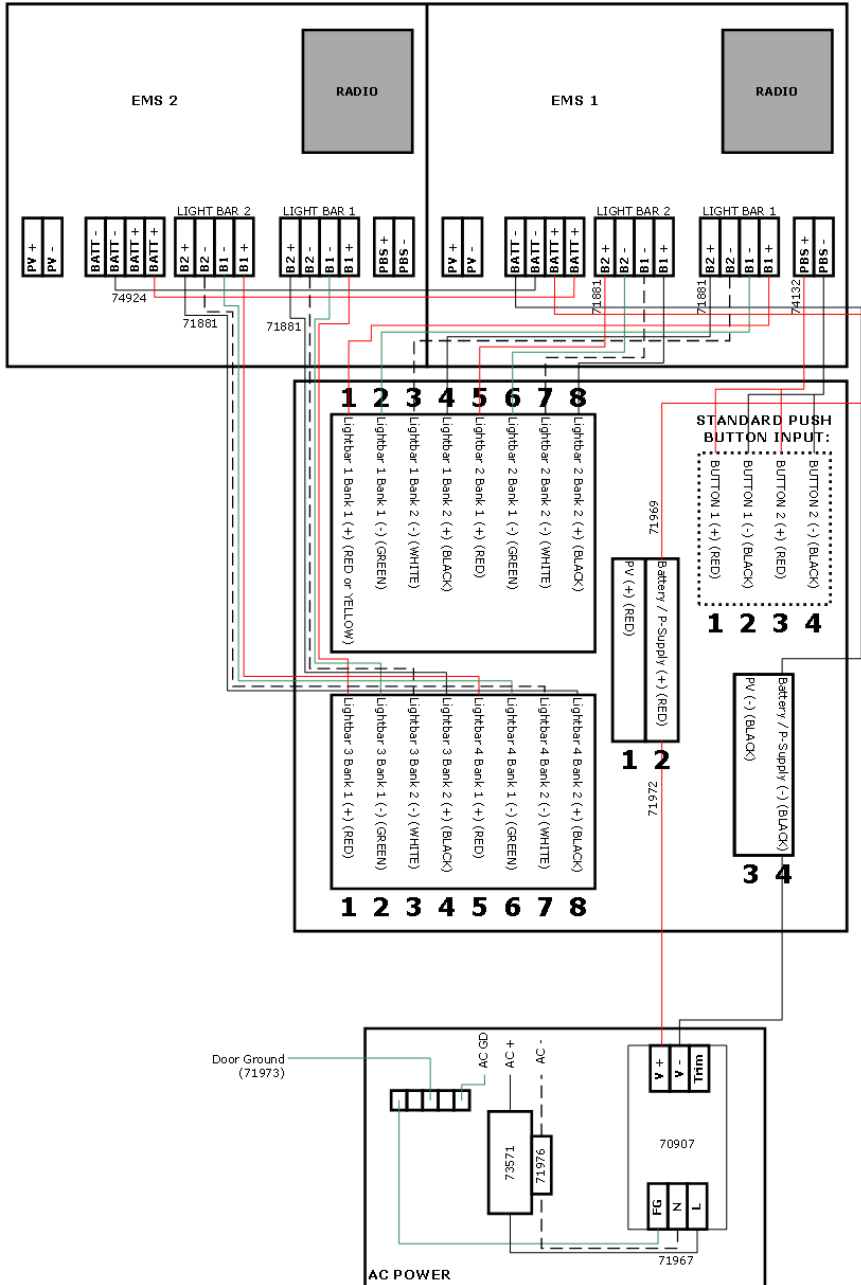

SC315 - AC POWER, 1/2 LIGHTBARS, TALKING

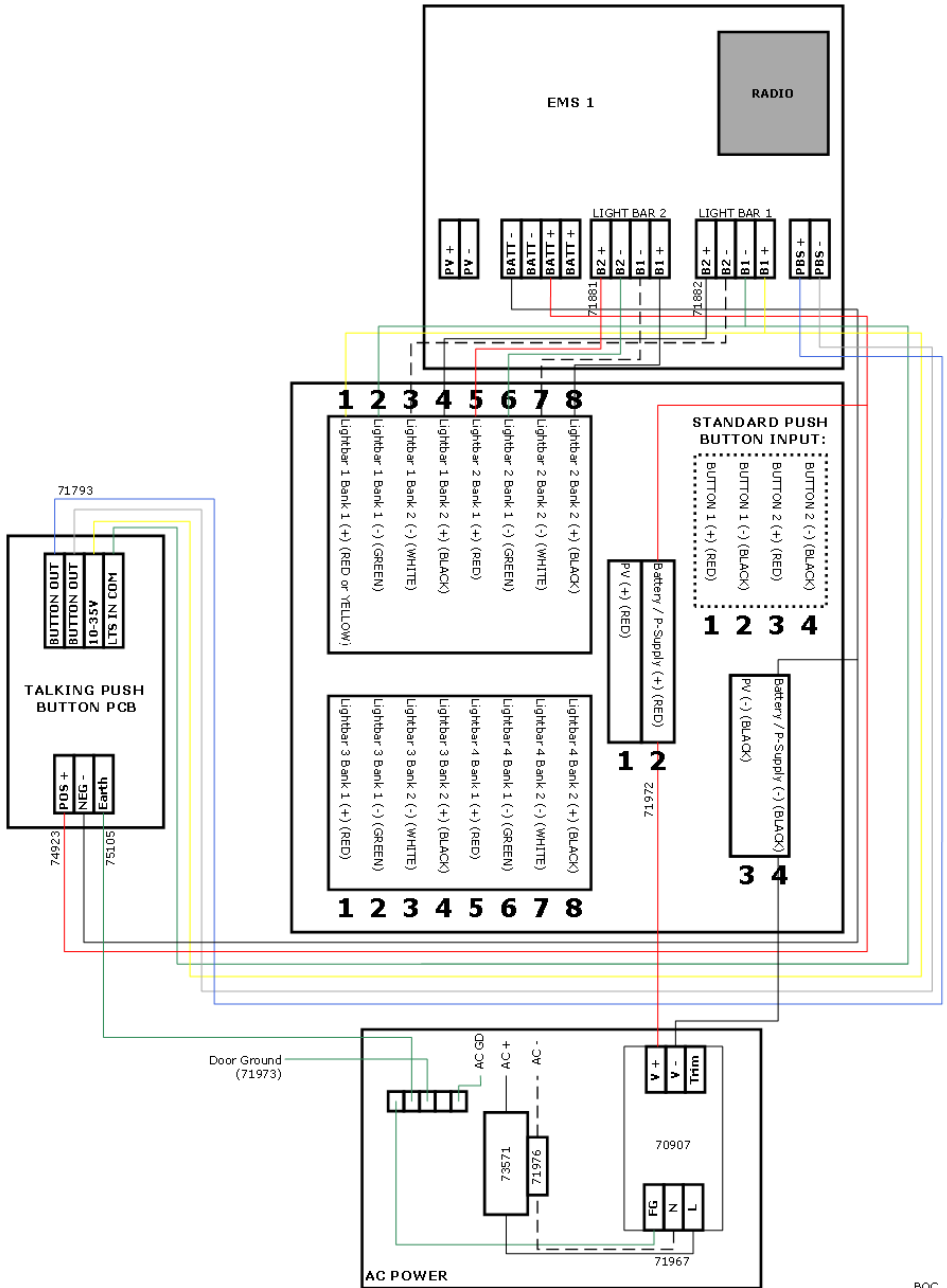

SC315 - SOLAR, 3/4 LIGHTBARS, TALKING

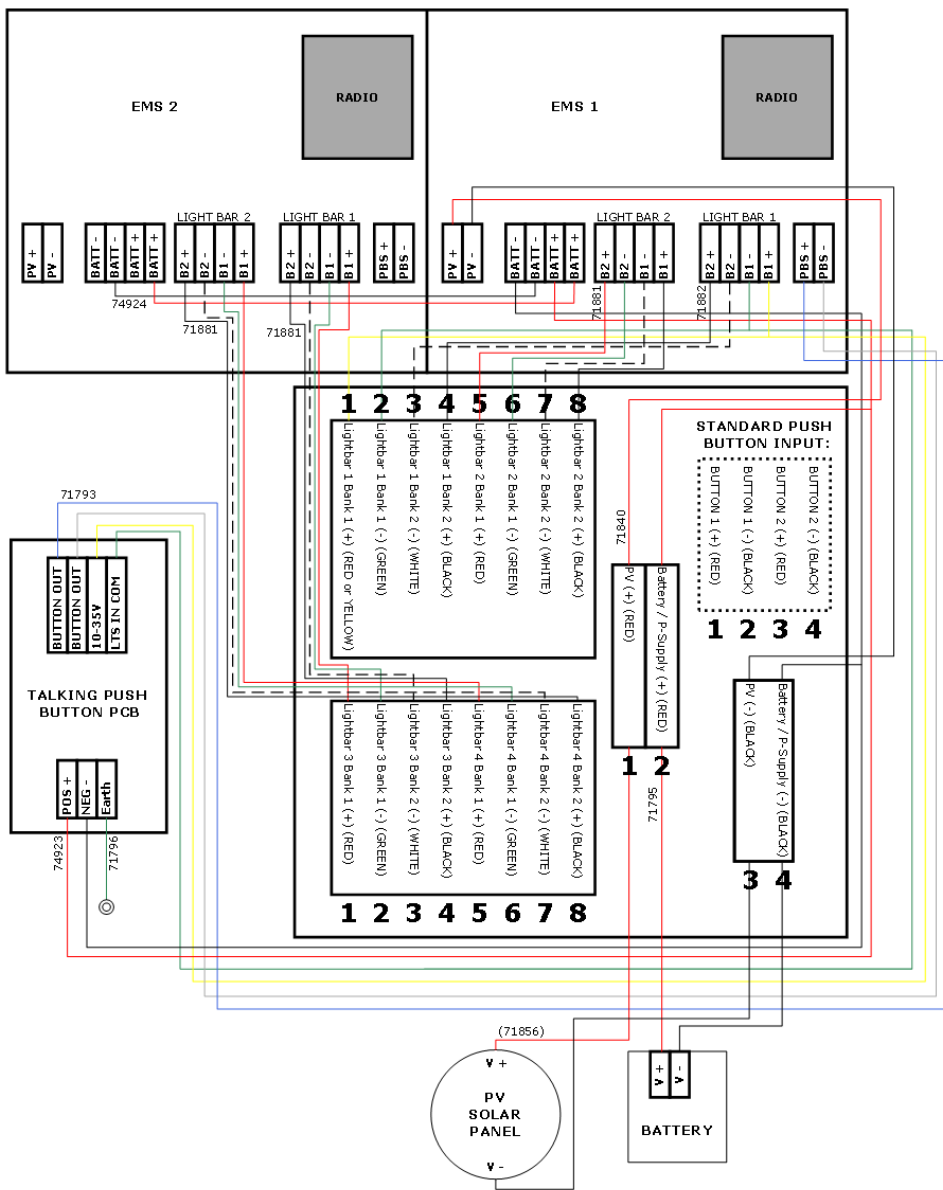

Summary

Basic steps to install a SC315 AC LED RRFB:

1. Mount the controller cabinet with the EMS to the pole.
2. Feed the AC supply into the cabinet and connect to the terminals.
3. Feed the light bar and push button cables down the pole.
4. Mount the LED light bar universal bracket(s) to the pole.
5. Mount the LED light bar(s) to the universal bracket(s), pulling the cables through the light bar and connect the wires to the LED's.
6. Aim the LED light bars to the traffic.
7. Mount the pedestrian push button to the pole, pulling the cable through the push button mount and connect the wires to the push button..
8. Activate and configure the EMS as required using the onboard user interface.

Step by Step Instructions

1

Feed the AC supply line into the cabinet and feed the light bar cable(s) and push button cable(s) from the cabinet down the pole.



Typical cabinet mounting location for bidirectional signage



Typical cabinet mounting location for unidirectional signage



2

Secure the controller cabinet to the pole using appropriate stainless steel banding. Banding not supplied.



NOTE: Enclosure may be mounted using the alternative mounting using optional Z-Bar mount and U-bolts. ASTM F593 grade U-bolts are supplied. See Miami Dade County hardware compliance requirements for details. Torque U-bolts to 90 inch-lbs

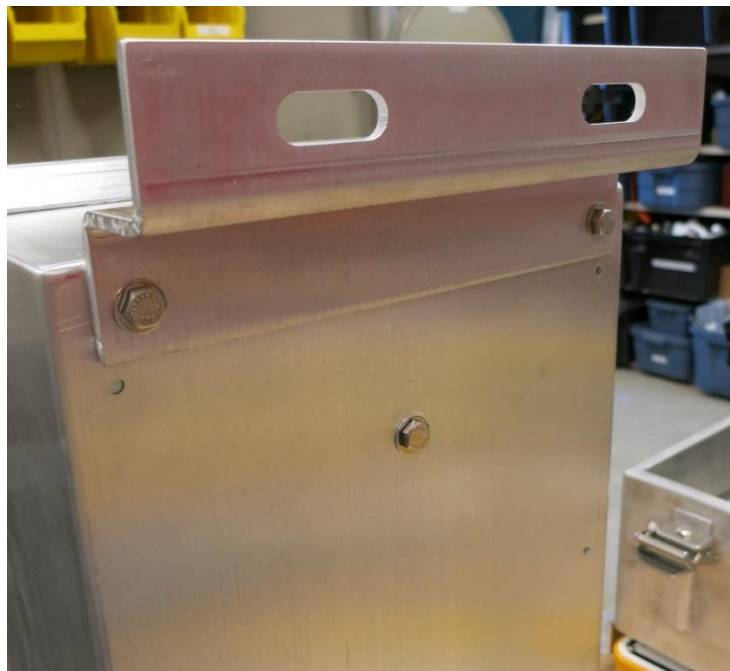

3

Connect the AC supply wires to the ground, circuit breaker and terminal block.



ELECTRICAL
SHOCK
HAZARD

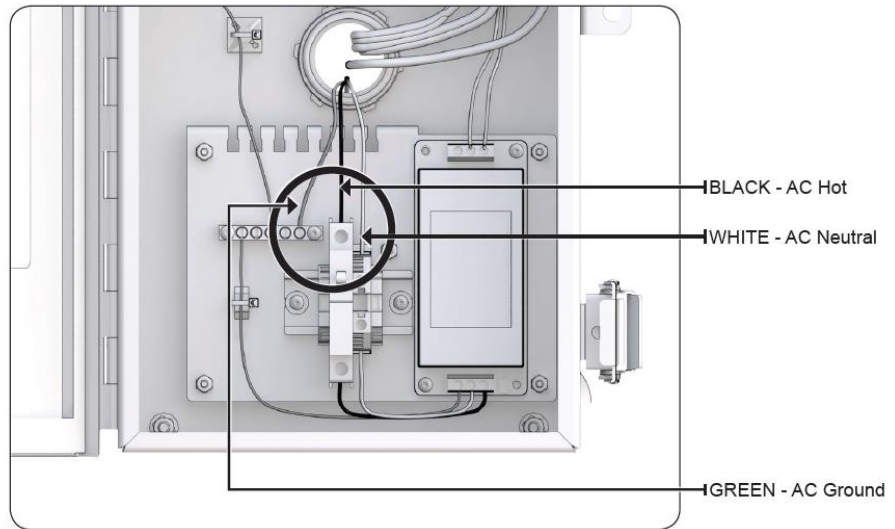

4

Feed the push button wires through the pole, creating a drip loop to prevent water ingress into the button.

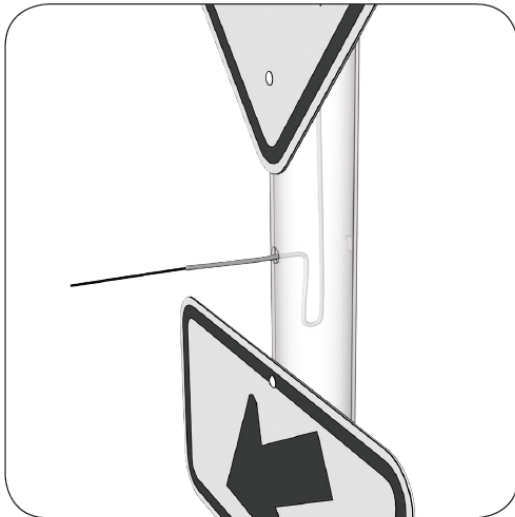

5

Mount the light bar universal bracket(s), feeding the light bar cable through the center of the bracket. Banding not supplied.

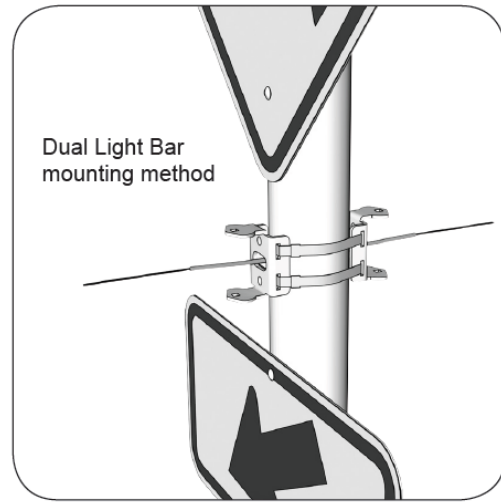
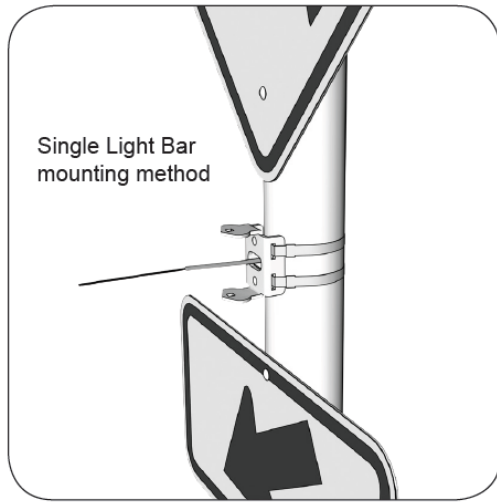

Note: Light bar mount may alternately be mounted directly to the pole into tapped holes. 5/16 X 3" bolts are recommended. Bolts are not supplied. Appropriate grade fasteners must be used according to local requirements. See Miami Dade County hardware compliance requirements for details. Torque these bolts to 100 inch lbs.

6

Mount the light bar(s) onto the universal bracket(s), feeding the light bar cable through the grommet in the housing.

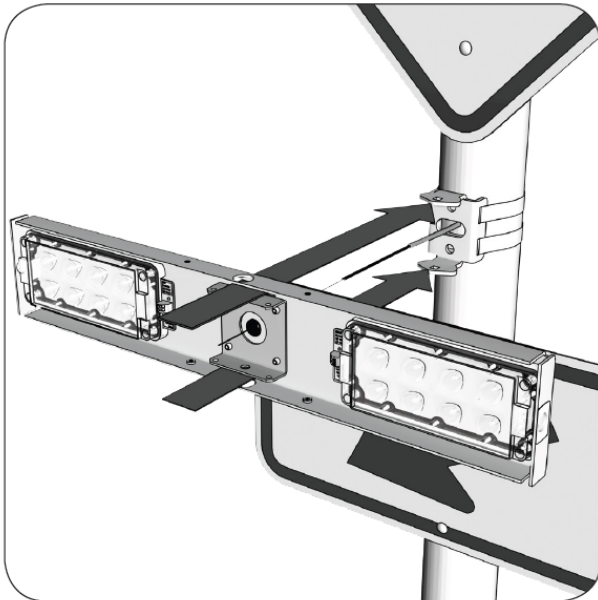

7

Bolt the light bar to the universal bracket.

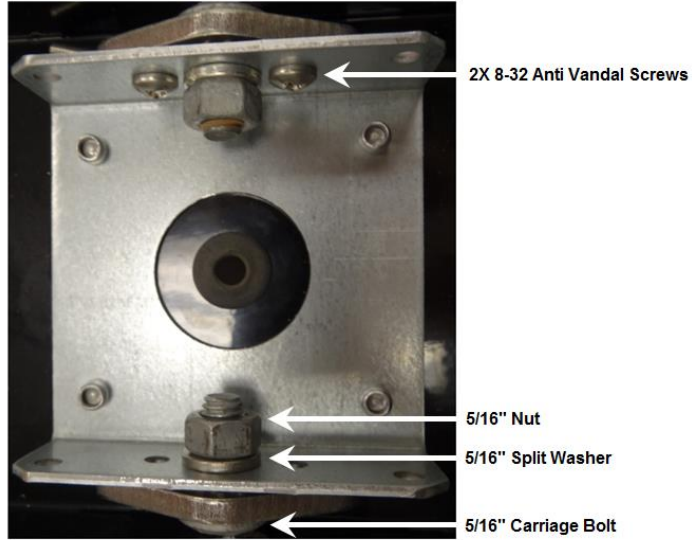

NOTE: Anti vandal screws allow for up to 3° of horizontal adjustment in both directions after the mount has been installed.

8

Align the light bar toward the traffic as required, and tighten mounting nuts to lock in place.

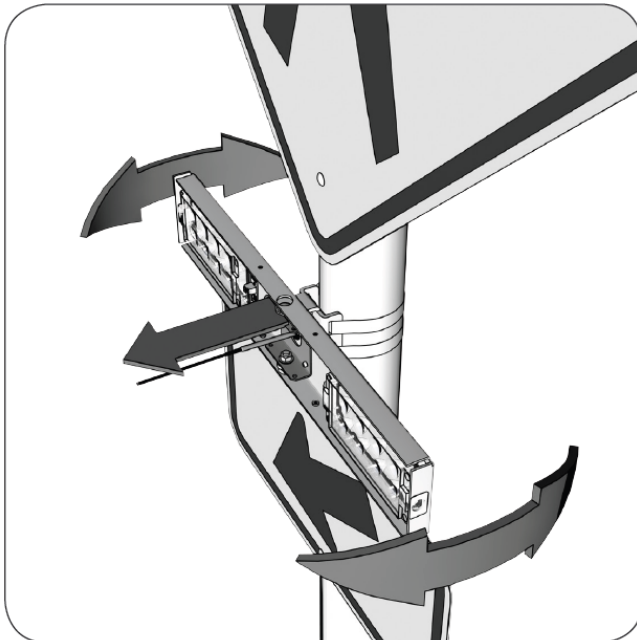

9

Secure the light bar cable using supplied cable ties as shown.

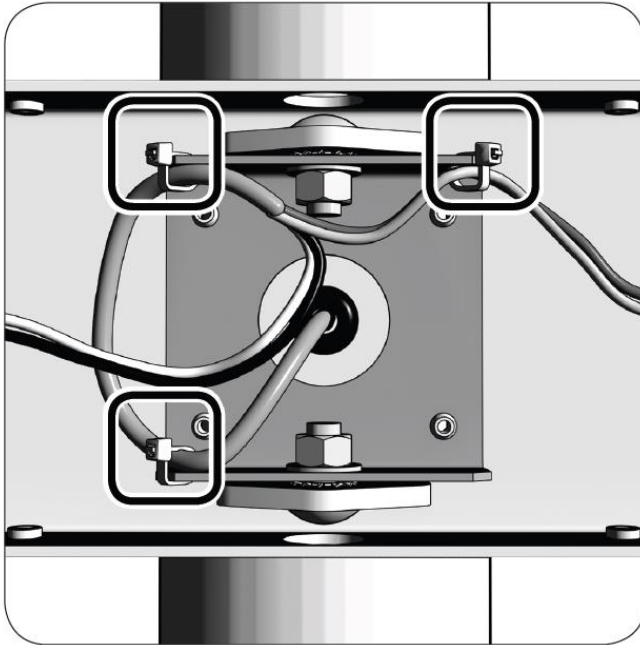

10

Push the light bar wires into the light bar connectors, following the color scheme as noted on LED.

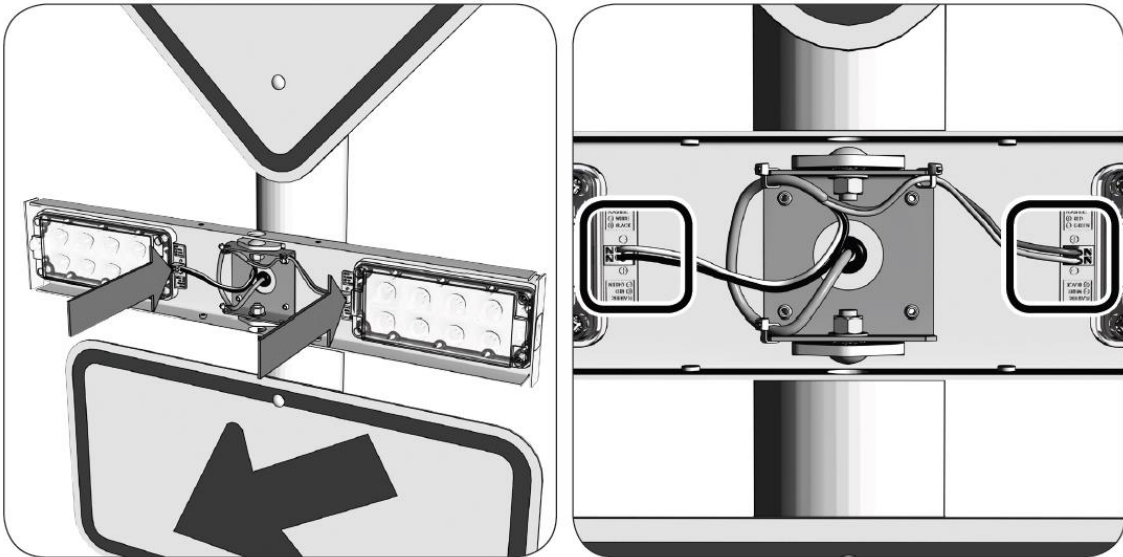

11

Slide on light bar cover and secure with provided screws.

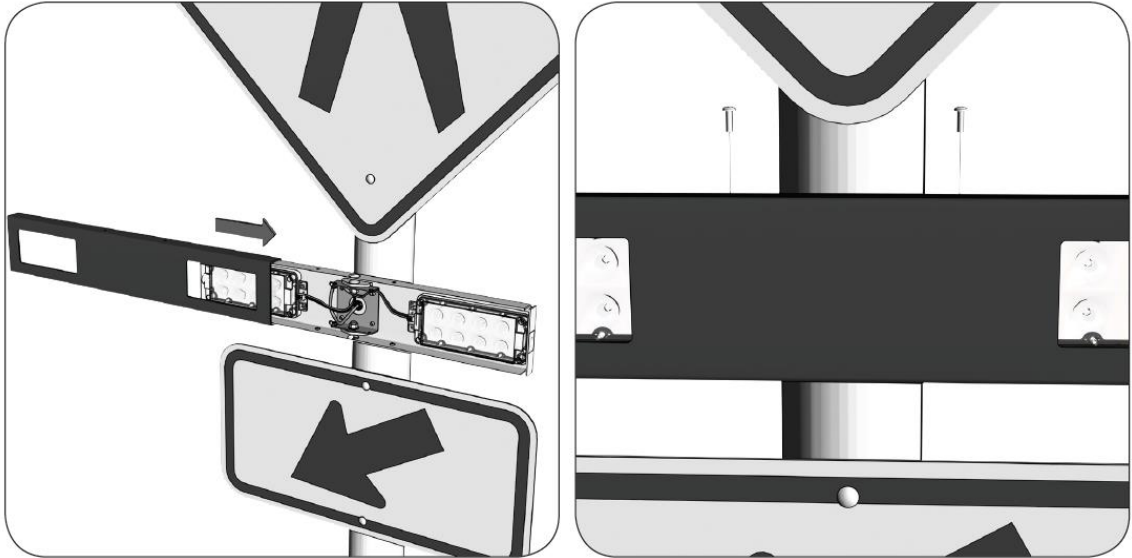

NOTE: Light bars with the backside painted black include 4 pin in Torx anti vandal screws. Two fasten to the top of the light bar, and two fasten to the bottom of the light bar. A T-15 Torx security bit is required to loosen the screws to gain access to the inside of the light bar.

12

If the pedestrian confirmation light is not required in one direction, use the supplied opaque label to cover the indicator light.

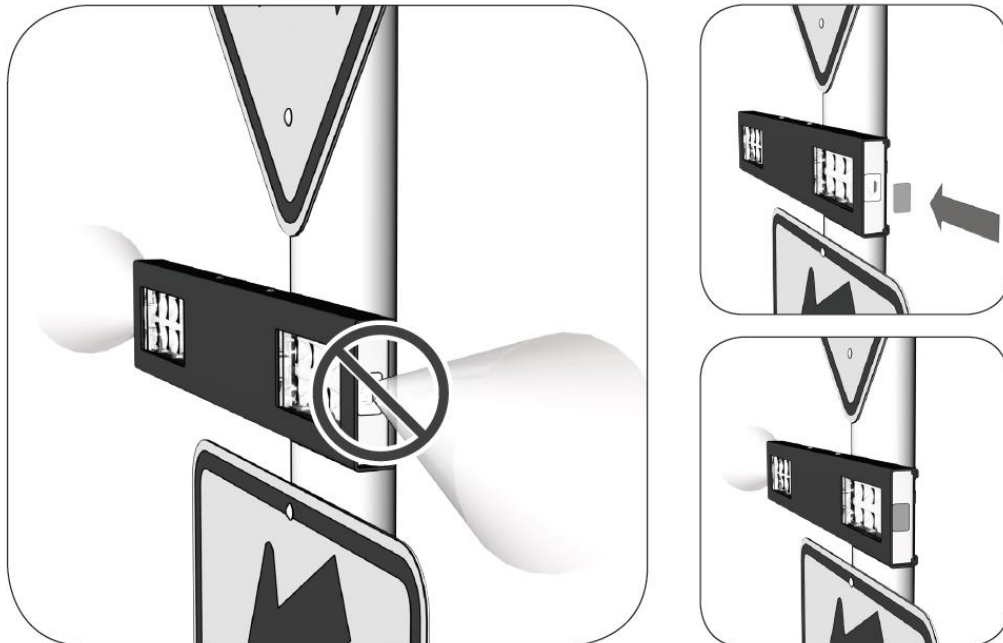

13

Feed the push button cable through the post, creating a drip loop.

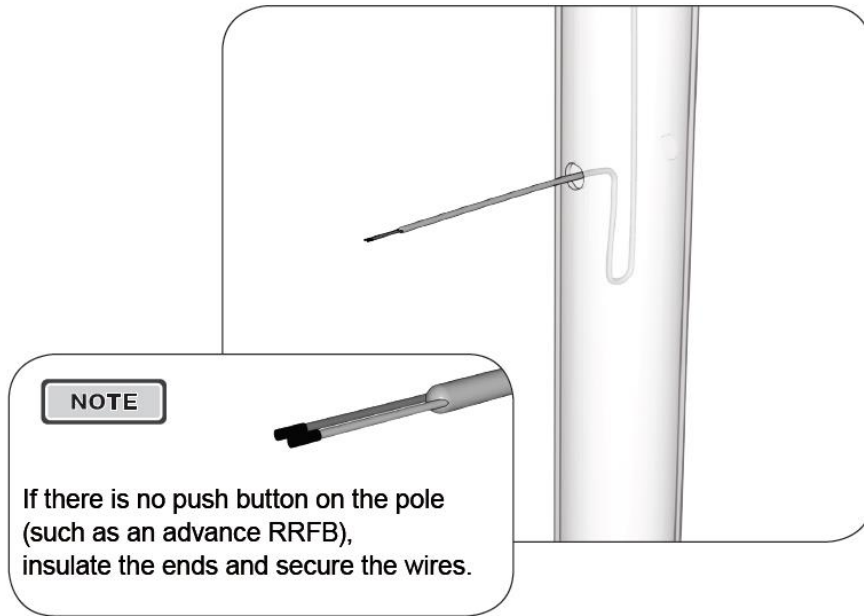

14

Attach the button mounting adapter to the pole, connect the button cable to the button and attach the button to the mounting adapter.

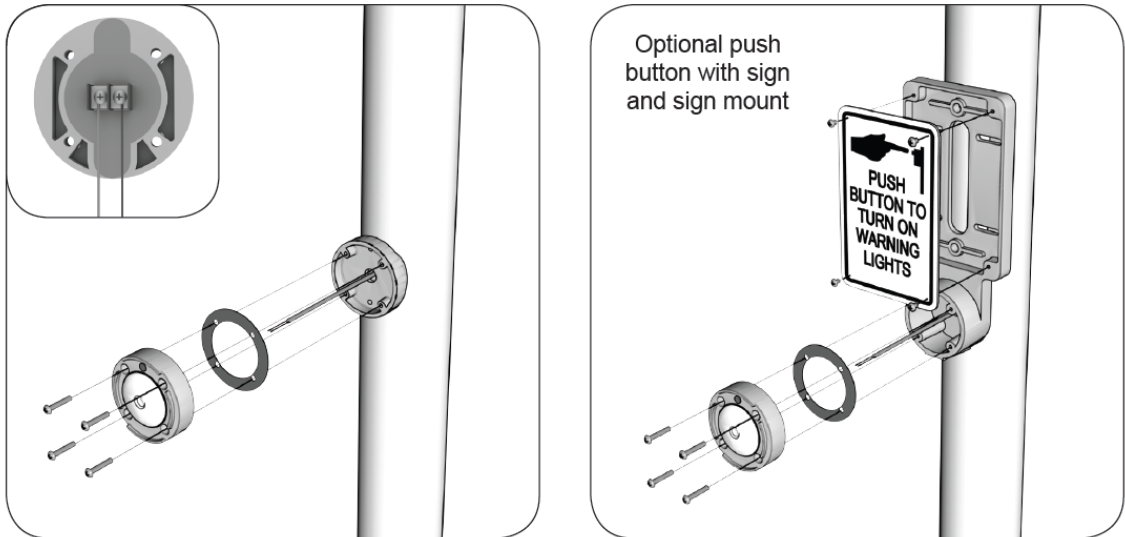

If the optional audible push button was ordered, there will be an additional controller card in the cabinet and the audible push button(s) will be included in the shipping box.

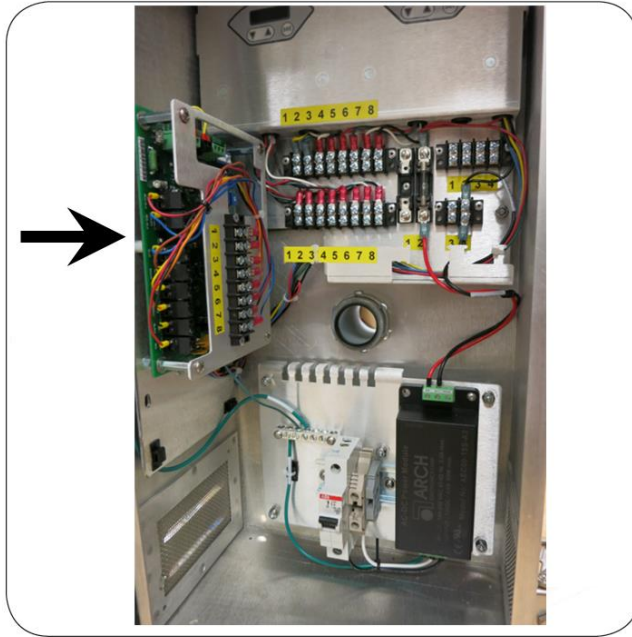

Install audible push button, running the cable from the pole, down the back of the button and into the compartment at the bottom of the button. Replace the button connection compartment cover.

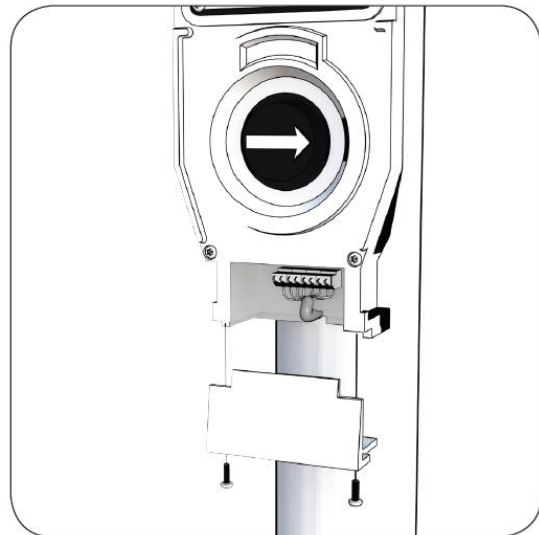
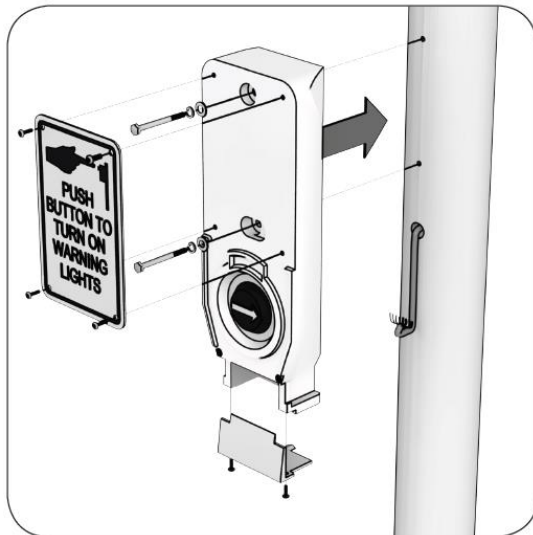

16

The system is factory programmed to operate and communicate to other units without configuration once the power is activated by switching on the circuit breaker. See 'EMS Programming and Testing' section to adjust default settings and to perform system testing.

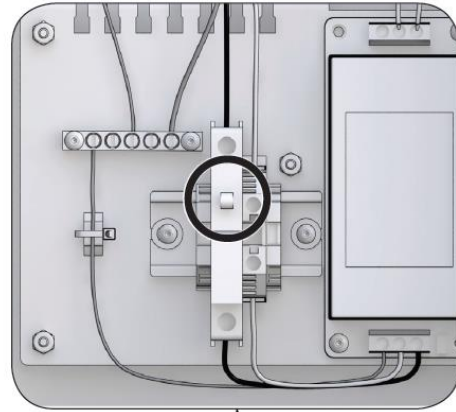
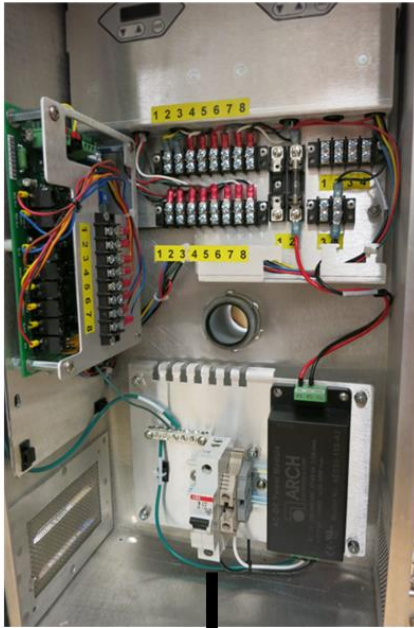

EMS Programming and Testing

The Energy Management System (EMS) has several programming functions and settings. These are accessed through the Onboard User Interface (OBUI). This section discusses the various functions, settings and operation.

EMS Onboard User Interface Operation

The EMS OBUI has three buttons to navigate and change settings and activate functions as required. The up button, down button and set button are used to scroll through menus, access and change settings, and accept new settings.



Use the up and down buttons to scroll through the menu.

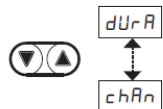

Press and hold the set button to edit a setting. The display will blink when the setting is ready to edit.



Use the up and down buttons to adjust the setting when in edit mode.

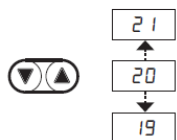

Press and hold the set button to accept the new setting. The display will flash 3 times to indicate the setting has been accepted.

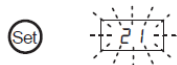

Note: When installing a new fully charged battery, press and hold the “set” button as you connect the battery. Continue to hold the “set” button until zero is displayed briefly. This resets the EMS battery pack health monitor.

Do not hold the “set” button while reconnecting a damaged, used, or depleted battery.

Note: The most accurate Battery Pack Health Status reading is obtained when the solar panel is either not illuminated or not connected and the battery has been disconnected for at least 24 hours.

Functions and Settings

The functions and settings are accessed through the OBUI via a menu system. Refer to page 26 for the menu hierarchy which includes a description of the functions and settings.

NOTE

Only these items in the menu system are adjustable settings: dUrA*, chAn, nItE*, AAA*, tEst, bArS, bISt

*Networked settings. Changes to these settings will affect all systems on the same radio channel.

Multi EMS Settings

The EMS is factory programmed based on the original requirements. If the system configuration is changed, settings may need to be updated to match the new configuration.

Single or Dual Light Bar Systems

A system designed to support single or dual light bars has a single onboard user interface. You can set the system to either have 1 or 2 light bars using the bArS setting. Setting the bArS to the correct quantity of light bars is essential for proper operation.

Three to Four Light Bar Systems

A system designed to support 3 to 4 light bars has an onboard user interface for light bars 1 and 2, and a second onboard user interface for light bars 3 and 4.

Changing the networked settings (dUrA, nItE, AAA) on one user interface will automatically change the setting on the other user interface. Non-networked settings (chAn, bArS) must be set on each user interface.

NOTE

The chAn setting must be set to the same channel on each user interface for proper operation.

You can set each EMS/User Interface to have 1 or 2 light bars using the bArS setting. Setting the bArS to the correct quantity of light bars is essential for proper operation.

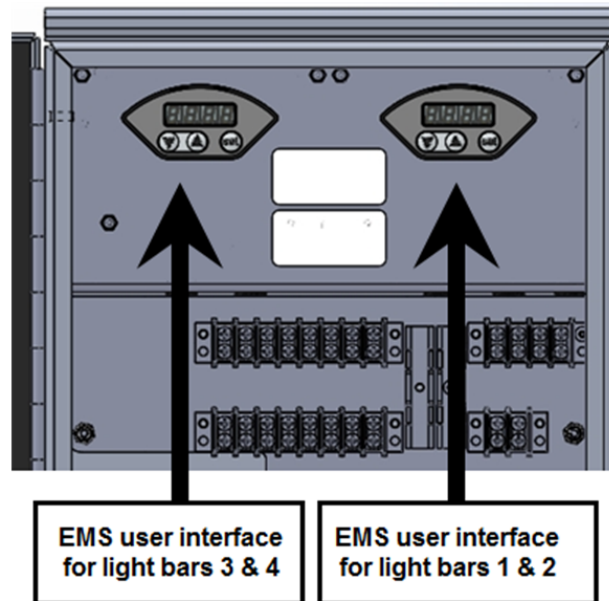
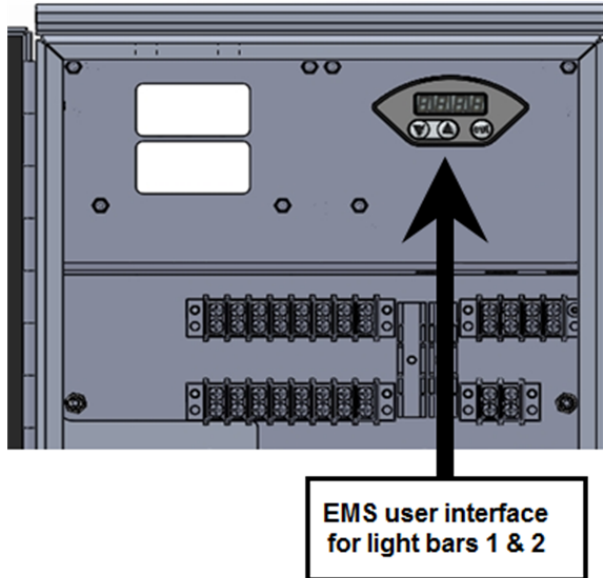

ALERT!	
	<p>LEd: LED flasher fault alert. This alert only appears if there is a problem with the LED flasher(s). Use the tESt function or press the pedestrian push button to clear the alert once the problem has been resolved</p> <p>SHrt: LED flasher is shorted. Correct the short to return to normal operation.</p> <p>oPEn: LED flasher has an open circuit. Check the LED wiring, correct the problem to return to normal operation.</p>
	<p>bAtt: Supply voltage status and voltage reading. When power is first turned on, the system will display this item, if no faults are present.</p> <p>good: Voltage from the AC/DC supply is good.</p> <p>chAr: Not used for AC powered systems.</p> <p>Lo: 12 volt supply from the AC/DC supply is below expected voltage.</p> <p>bAd: Not used for AC powered systems.</p> <p>00.00: Supply voltage, displayed in volts. Should be above 12.0 V.</p>
	<p>SoLr: Solar sensor status.</p> <p>ni tE: Solar sensor is not detecting light (nighttime). This can be simulated by covering the ambient light sensor on top of the engine.</p> <p>dAY: Solar sensor is detecting light (daytime).</p> <p>00.00: Solar panel voltage. Not used for AC powered systems.</p>
	<p>dUrA: Duration of the flash. The system will flash for the set number of seconds after a pedestrian push button has been pressed.</p> <p>20: Duration in seconds, ranging from 10 to 60 seconds, in 1 second increments.</p>
	<p>chAn: Radio channel for synchronized systems. This channel must be the same on all systems in order for them to synchronize.</p> <p>5: Selected channel, range from 1 to 16. Factory default is 5.</p>
	<p>ni tE: Nighttime dimming level. During the darkness of night, the system will dim to this level as full brightness is not required.</p> <p>30: Percent of daytime level, from 10 to 50%.</p>
	<p>AAA: Ambient light auto-adjust settings. The system will automatically adjust to the surrounding light conditions when the AAA is on.</p> <p>on: Ambient light auto-adjust is on.</p> <p>off: Ambient light auto-adjust is off.</p> <p>10: Ambient light auto-adjust dim level. Reports what the current adjustment level is, ranging from 1 to 10.</p>
	<p>ALc: Automatic light control energy savings level. Not used for AC powered systems.</p> <p>100: 100% indicates normal operation.</p>
	<p>tESt: Test the system and clear any fault warnings.</p> <p>YES: Tests the system by activating the LED flashers.</p> <p>no: Skips the test, does not clear any warnings.</p>
	<p>bttn: Button press detection status. If a button was recently pressed, it will display dEt to help troubleshoot and test the system.</p> <p>no: No button press detected.</p> <p>dEt: Button press was detected.</p> <p>Shrt: Short detected in button or harness.</p>
	<p>rAdo: Radio installed status. If the system is able to find and activate a radio, it will display dEt.</p> <p>dEt: Radio is installed.</p> <p>no: No radio was detected.</p>
	<p>Act: Activation count. Counts the number of activations and averages the last 90 days.</p> <p>0: Average daily activations over last 90 days.</p>
	<p>bArS: Number of LED flasher bars connected. Set this to match the number of LED flasher bars connected to the Solar Engine.</p> <p>2: The number of LED flasher bars, 1 or 2.</p>
	<p>biSt: Built in system test.</p> <p>YES: Activates the built-in system test.</p> <p>no: Skips the built-in system test.</p>
	<p>vEr: Firmware version number.</p> <p>0.0.0.0: The firmware version number.</p>

System Testing

Testing the LED Flashers

The OBUI has a test function (tEst, see previous section) that activates the flashers independently of a physical push button test. Activating this function through the OBUI, as described in the previous section, will operate the flashers for the set period of time. If this activates the flashers properly, and the flashers will not operate with the pedestrian push button, then there may be a fault with the push button or the wiring to the button.

Built-in System Test

The OBUI has a built-in system test function (bISt, see previous section). Activating this function through the OBUI, as described in the previous section, performs the system test. After the test completes, it will display any errors or 'PASS' if no error is detected.

Possible errors include:

Code	Error
0002	Severe temperature detected
0004	Onboard processor has failed
0010	There is a problem with the supply voltage
0020	Keypad failure detected
0040	Internal communication failure
0080	There is a problem with the ambient brightness sensor
0200	There is a problem with the flashing light bars

LED Fault Message

The EMS performs an internal test during start up to check for any shorts or open circuits in the LED flashers and the associated wiring. This message is displayed on the OBUI before any other menu item. Use the tEst function or press the pedestrian push button to clear the alert once the problem has been resolved.

Setting the Radio Channel

In order for the entire crosswalk set to operate when a pedestrian push button is activated, the SC315 utilizes an on board radio to communicate to the other units that make up the crosswalk set. The radio channel for all of the units must be set to the same radio channel. Adverse behavior will result if the same radio channel is not set on all of the units in a crosswalk set.



If there are two crosswalks set in close proximity to each other, but are intended to operate independently, then a different radio channel for each set will be required. The factory default for the radio channel is 5.

Radio Network Settings

Some of the EMS settings are synchronized across the units in a crosswalk set on the same channel.

Once the networked setting is changed on one system, the networked settings will be transmitted and synchronized with the system that was just updated.



If there are two crosswalks sets in close proximity to each other and on the same radio channel, the networked settings may be transmitted and synchronized with the system that was just updated.

These settings are synchronized across the crosswalk set: dUrA, nItE, AAA. See the Functions and Settings section for an explanation on these settings.

NOTE

Changes to the networked settings can be made from any one of the units in a crosswalk set.

Maintenance & Product Care

The SC315 engine is designed to operate reliably for years with virtually no need for maintenance. Carmanah recommends routine inspections of the system to ensure that they are operating properly.

The frequency of the inspections depends on location and local weather patterns. A yearly visual inspection of the SC315 is typically sufficient. The SC315 is designed to be maintenance free, however maximum system performance will be achieved when the LED lenses are clean.

EMS Recycling

Production of the EMS required the extraction and use of natural resources. The EMS may contain substances that could be harmful to the environment or human health if improperly handled at the product's end of life. In order to avoid release of such substances into the environment and to reduce the use of natural resources, we encourage you to recycle the EMS in an appropriate way that will ensure most of the materials are reused or recycled appropriately. Check your local municipality for electronics recyclers.

Troubleshooting

Symptom	Possible Cause - What to Check
The EMS does not activate, does not display any information, or the system does not activate.	<p>This is typically caused by low or no voltage.</p> <p>Check the circuit breaker. If the circuit breaker has tripped, check the power feed and wiring for issues.</p> <p>Check the DC supply voltage either through the OBUI or with a voltmeter. See the EMS Programming and Testing section of this manual.</p>
LEDs won't flash when button on same post is pressed	<p>This can be caused by either button failure, a wiring issue, no supply voltage, or the unlikely event of an EMS failure.</p> <p>Check to insure that the button is functioning and it is providing the typical feedback. If the button has an LED or audio feedback, ensure that these are working.</p> <p>Check the wiring to the button for continuity and make sure the wires are not pinched anywhere along their length.</p> <p>Check the wiring to the LED Light Bars for continuity and make sure the wires are not pinched anywhere along their length.</p> <p>Check that the wiring pattern (polarity) is correct on the LED Light Bars.</p> <p>Check the supply voltage, either through the OBUI or with a voltmeter (see item above)</p> <p>Check the OBUI for errors. See the EMS Programming and Testing section of this manual.</p> <p>Test the system using the OBUI 'tEst' function. See the EMS programming and testing section of this manual. If the LEDs flash using the OBUI functions, then the problem is in the button or wiring to the button.</p>
LEDs on same post flash, but other systems in the crosswalk set won't flash	<p>The SC315 communicate via a radio. If one system is activated, but the other systems in the crosswalk set are not coming on, this points to a radio issue.</p> <p>Ensure that all of the units in a crosswalk set are set to the same radio channel using the OBUI. See the EMS Programming and Testing section of this manual.</p> <p>Ensure that the units in a crosswalk set are not too far apart. The maximum distance for proper radio communication is 500 unobstructed feet. There can be no barriers or obstructions between systems, such as buildings or billboards.</p>
One Light Bar flashes, but the other Light Bar on the same post does not flash	<p>This is likely caused by improper wiring of the light bars.</p> <p>Ensure that the wire colors match the instructions on the Rectangular Flashers and in this manual. If they do not match then one light bar may not activate.</p>
One Rectangular Flasher flashes, but the other Rectangular Flasher on the same light bar does not flash	<p>This is likely caused by incorrect wiring on the LED Light Bars.</p> <p>Check each of the connections at the Rectangular Flashers to ensure correct wiring pattern (polarity).</p>

Symptom	Possible Cause - What to Check
The LEDs are dim when flashing	<p>The supply voltage may be too low for proper operation. Check the OBUI for status and voltage. See the EMS programming and testing section of this manual.</p> <p>Check for debris covering the Ambient Light Sensor on top of the Solar Engine.</p> <p>Set the number of light bars to the correct value on the OBUI. See the EMS Programming and Testing section of this manual.</p> <p>Check the Ambient light Auto-Adjust (AAA) setting on the OBUI. Turn off the AAA to see if this corrects the dim LEDs. See the EMS programming and testing section of this manual.</p>
The LEDs appear too bright when flashing	<p>Settings on the EMS can affect the apparent brightness of the LEDs.</p> <p>Set the number of light bars to the correct value on the OBUI. See the EMS Programming and Testing section of this manual.</p>
Lights flash when no button is pressed	<p>This is likely caused by another nearby system on the same radio channel activating this system.</p> <p>Ensure that all of the units in a crosswalk set are set to the correct radio channel using the OBUI, ensuring that nearby systems at a different location are using a different channel. See the EMS Programming and Testing section of this manual.</p>

Specifications

Mechanical Specifications	
Cabinet Dimensions	
Width	10.5" (267 mm)
Depth (not including mount)	6.5" (165 mm)
Height	19.5" (495 mm)
Weight	11 lbs (5 kg)
Light Bar Dimensions	
Width	24" (610 mm)
Depth (not including mount)	1.5" (38 mm)
Height	4.5" (114 mm)
Weight	4 lbs (1.8 kg)
Electrical Specifications	
System	
Supply Voltage	120VAC
System voltage	12V (nominal)
Overcurrent Protection	
Circuit Breaker	4 A
Fuse	7 A
Fuse Type	3AG (1/4" x 1-1/4")
Solar Charge Controller	
Type	Maximum power point tracking 3 stage temperature compensated
LED Driver	
Type	Constant current, buck - boost
Max output voltage	33 Vdc
Max output current	300 mA
Environmental	
Maximum wind zone deployment	150 mph
Operating temperature range	5 to 122° F (-15 to 50° C)

Miami Dade County Hardware Compliance Requirements:

- 1) Nuts, bolts and washers used to mount the light bars must be Type 304 or 316 stainless steel. Light bars must be bolted to the pole mounting surface through a tapped hole using type 304 or 316 stainless steel flat and lock washers. Banding is not permitted. Minimum bolt requirement is for two type 304 or 316 stainless steel 5/16"-18 bolts which meet the requirements of ASTM F593 with a minimum yield strength of 65KSI. Bolts shall be torqued to 100 inch lbs.
 - 5/16" Bolts not supplied with light bar for mounting directly to pole.
- 3) Only the cabinet Z-bar mount may be used. Minimum bolt requirement is for two type 304 or 316 stainless steel 1/2"-13 U-bolts meeting the requirements of ASTM F593 with a minimum yield strength of 65KSI. Type 304 or 316 stainless steel lock washers shall be used with the U-bolts. The corresponding 1/2" nuts must meet the requirements of ASTM F594. U-bolts shall be torqued to 90 inch-lbs.
 - Z-bar mounts are provided with these appropriate U-bolts.
- 4) Four type 304 or 316 stainless steel 8-32 x 0.5" pin in torx head anti vandal security screws are to fasten the outer cover of the light-bar. Two 304 or 316 stainless steel 8-32 X 3/8" Philips head machine screws in the light bar mount are to be used to set the position of the light bar.
 - Light bars with the backside painted black are provided with these 4 appropriate pin in Torx anti vandal screws.

Warranty

This product is covered by the Carmanah warranty. Visit www.carmanah.com for additional information or contact the customer service department.

Before contacting Carmanah's customer service department, please have the serial number of your system available, a brief description of the problem, as well as all details of the installation.

To contact Carmanah's Customer Service Department:

Mail: Carmanah Technologies Corporation
250 Bay Street
Victoria, BC Canada V9A 3K5

Phone: 1.250.380.0052
877.722.8877 (Toll Free in U.S. and Canada)

Fax: 1.250.380.0062

Email: customerservice@carmanah.com

Website: carmanah.com