

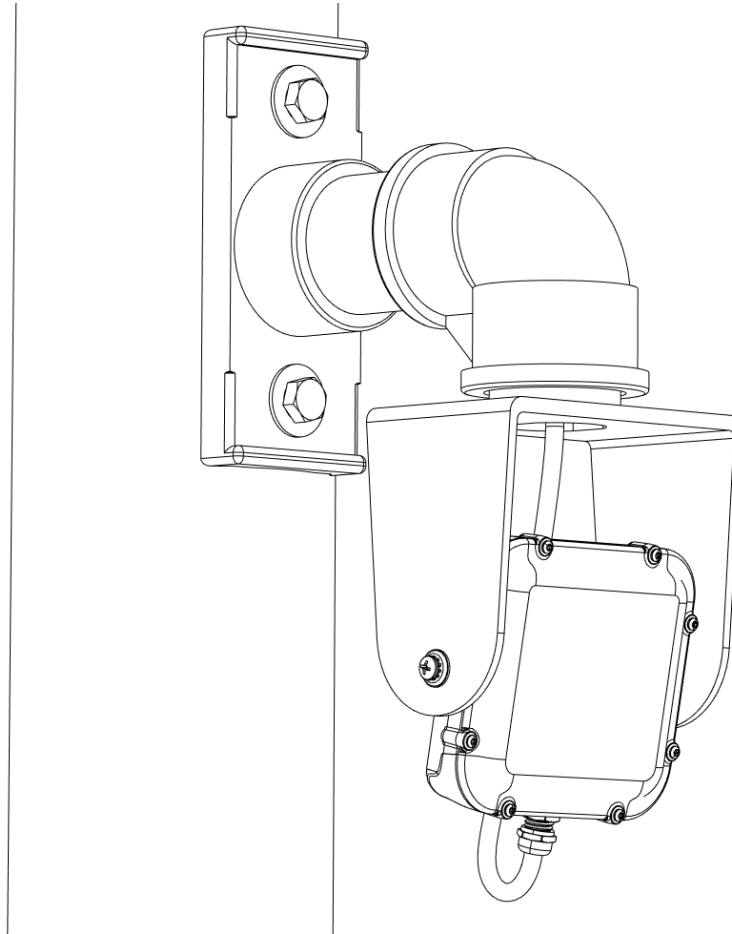

Radars Detection Kit USER MANUAL

For Carmanah E, F and G Series and WW200 Traffic Beacon Systems



89824_MANUAL_TRA_Radar-Detection-Kit_RevA

Table of Contents

1.0 Warnings and Precautions	3
1.1 Warranty Disclaimer	3
1.2 Standards	3
1.3 Safety and Usage Precautions	3
2.0 Radar Detection Kit Components	4
3.0 Operation.....	5
3.1 Radar Module Operation	5
3.2 Wireless Operation	5
4.0 Installation.....	6
4.1 Determine Installation Location on Pole	6
4.2 Install Carmanah E, F or G system on Pole	6
4.3 Drill Holes for Radar Cable and Mount Through Bolts	7
4.4 Fish Radar Cable, Install Radar & Mount to Pole.....	7
4.5 Aim Radar Module	8
4.6 Connect and Configure Radar Module	9
4.7 Test System.....	10
5.0 Maintenance and Product Care.....	10
6.0 Radar Module Connection & Settings	11
6.1 Connecting to the Radar Module	12
6.2 Syncing radar clock to computer	13
6.3 Adjusting Speed Detection Limits and Sensitivity	14
6.4 Adjusting Trigger Output Configuration	15
7.0 Troubleshooting	16

1.0 Warnings and Precautions

The following symbols indicate important safety warnings and precautions throughout this manual:



WARNING indicates that serious bodily harm or death may result from failure to adhere to the precautions.



CAUTION indicates that damage to equipment may result if the instructions are not followed.



NOTE suggests optimal conditions and provides additional information.

1.1 Warranty Disclaimer

This manual will familiarize you with the features, operation standards and installation of Carmanah's Radar Detection Kit. Failure to comply with the use, storage, maintenance, installation or placement instructions detailed in this manual could void the warranty.

1.2 Standards

Perform all installation, wiring, grounding and maintenance in conformance with local building and electrical codes. Adherence to the National Electrical Code (NEC) is mandatory to comply with any certification markings. Non-adherence to code may void the warranty.

1.3 Safety and Usage Precautions



Ensure the equipment is not powered during installation and wiring of the system. Recheck all completed wiring for proper polarity prior to energizing the system.



Perform all installation, wiring, grounding, and maintenance in conformance with local building and electrical codes. Adherence to the National Electrical Code (NEC) is mandatory to comply with any certification markings. Non-adherence to code may void the warranty.



Changes or modifications to Carmanah equipment not expressly approved by Carmanah could void both the user's authority to operate the equipment and the warranty.

2.0 Radar Detection Kit Components

The Radar Detection Kit is used to activate one or more Carmanah beacon systems when a moving vehicle is detected. Applications include wrong-way driver systems, LED-enhanced stop signs, railroad crossing beacons and intersection conflict warning beacons.

When ordered with the Advanced Statistics option, the radar module collects and saves vehicle traffic data that can be downloaded and analyzed. For instructions on the use of this option see the associated user manual included with the system.

The Radar Detection Kit's components are shown and described below:

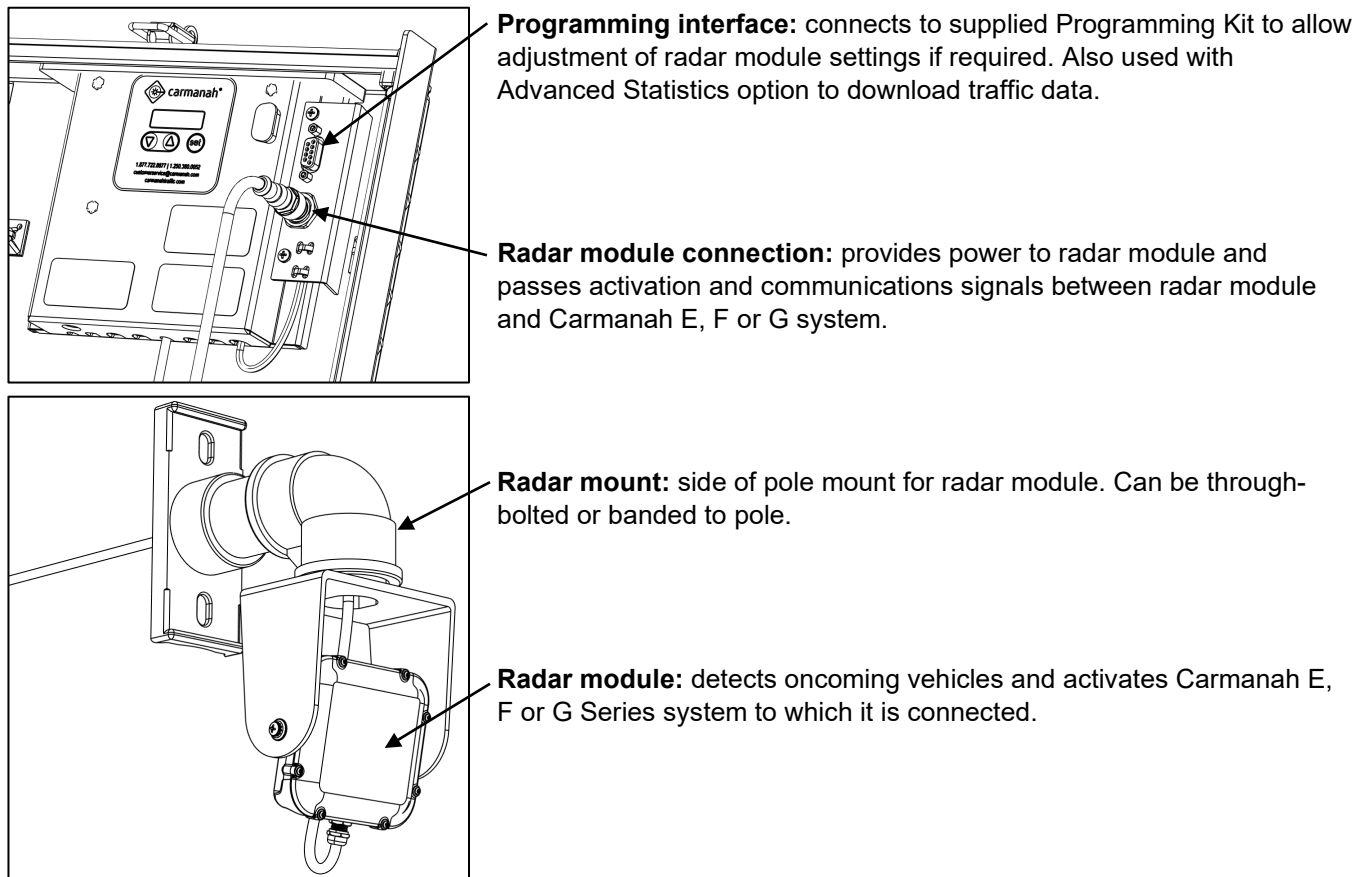

Mount hardware kits: contain different band clamps or bolts, nuts and washers to install the radar mount to different pole types and sizes.

Programming kit: allows adjustment of radar module settings. With the Advanced Statistics option, allows for download of traffic data. Includes a communications adapter and PC USB interface cable. One kit can service any number of systems equipped with the Radar Detection Kit; one typically provided per order.

3.0 Operation

When used with a single non-wireless Carmanah E, F or G system, the Radar Detection Kit triggers the system's RRFB light bar(s), beacon(s), or LED enhanced sign(s) to flash for a pre-set field-adjustable duration (see Output Hold Time setting, [Section 6.4](#)). When installed with two or more Carmanah E, F or G wireless systems, one or more Radar Detection Kits can activate all the systems' RRFB light bars, beacons, and LED enhanced signs.

3.1 Radar Module Operation

When the radar module detects the motion of a vehicle, it shorts the button input terminals of the Carmanah Energy Management System (EMS) to which it is connected. Once the radar module stops detecting the vehicle's motion, either because the vehicle has stopped or has moved out of the detection zone, it continues to hold the button input shorted for the duration programmed in the module's Output Hold Time setting ([Section 6.4](#)). The default setting is 10 seconds.

NOTE

The EMS in any E/F/G system with the radar detection kit is configured to turn on the system's LED loads whenever its button input is shorted (EMS Input Type set to "יָחַד", normally open).

3.2 Wireless Operation

When a radar-equipped wireless E/F/G system detects a vehicle, the EMS broadcasts a signal to flash any remote wireless E/F/G systems present. Once the radar-equipped wireless system stops flashing, its EMS broadcasts another signal to immediately extinguish the flashing of the remote systems.

The wireless Carmanah EMS can operate on 14 different Radio Channels. Wireless E/F/G systems will only communicate with one another if they're on the same Radio Channel. The Radio Channel is by default set to Channel 5 and can be changed using the on-board user interface (see the E/F/G User Manual for details). Radio Channels can be used to create groups of E/F/G systems that flash together but don't activate nearby systems set to a different Radio Channel.

Multiple radar-equipped wireless E/F/G systems can be used together. If you wish all systems to flash whenever a vehicle is detected by any of the radar-equipped wireless E/F/G systems, the EMS Radio Channel must be set to the same value in all systems (see E/F/G User Manual for details).

NOTE

The default EMS Radio Channel setting is Channel 5. Unless this is changed on any of the units, all wireless E/F/G systems will flash together.

4.0 Installation

The following tools and materials may be required to mount the Radar Detection Kit:

a. Drill and drill bits b. Socket set	c. Screwdriver d. Fish tape
--	--------------------------------

The following is a summary of the installation sequence of the Radar Detection Kit:

1. Determine installation location on pole for Radar Detection Kit
2. Install Carmanah E, F or G system on pole per supplied instructions
3. Drill holes for radar cable and bolts, if required
4. Fish radar cable, install radar & mount to pole
5. Aim radar module
6. Connect and configure radar module if required
7. Test system

4.1 Determine Installation Location on Pole

The radar module should be mounted on the pole so that its front face directly faces and has an unobstructed view of oncoming traffic. The radar module cable is 9.8 ft (3.0 m) long. To allow sufficient cable slack, the vertical distance between the radar mount and the E/F/G system should be at most 7 ft (2.1 m).

For optimal radar performance:

- For maximum range, mount radar at least 6 ft (1.9 m) above the ground
- Minimize the angle between target traffic and the radar module

NOTE

If the radar module can't be located near the side of the road, it may need to be pointed further up the road to detect vehicles effectively.

4.2 Install Carmanah E, F or G system on Pole

Use the instructions supplied with your system to install the Carmanah E, F or G system onto the pole.

NOTE

When multiple wireless Carmanah E, F or G systems are triggered by one or more systems equipped with the Radar Trigger Kit, ensure the systems are set to the same radio channel. See the Carmanah E/F/G Series User Manual at support.carmanah.com for details.

4.3 Drill Holes for Radar Cable and Mount Through Bolts

If routing the radar cable inside the pole, drill a 5/8" hole (16 mm) in the center of where the radar mount will attach to the pole. If through-bolting the radar mount, drill two 7/16" (11 mm) holes above and below as shown, through both sides of the pole.

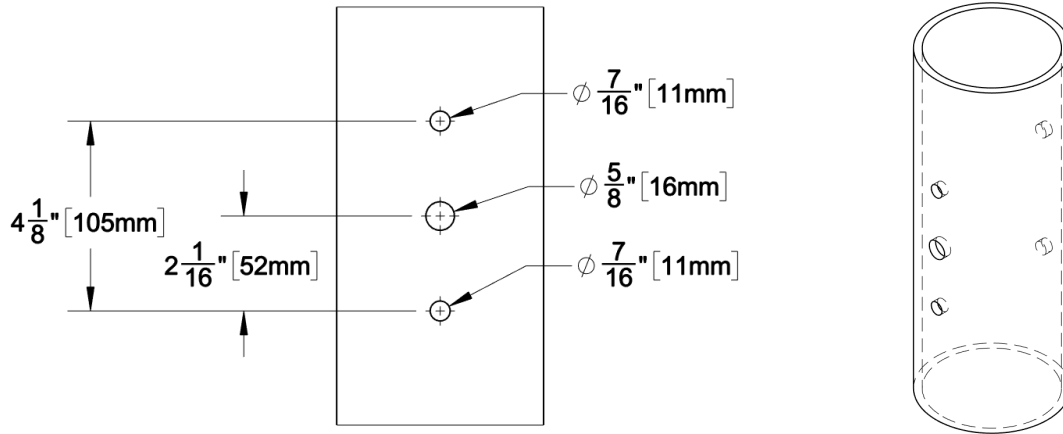

4.4 Fish Radar Cable, Install Radar & Mount to Pole

Install the radar module into the mount saddle with the cable facing down and fasten with the supplied spacers, washers and screws as shown. Fish the radar cable through the mount, into the pole and up or down to the Carmanah E/F/G system. Bolt or band the radar mount to the pole.

NOTE Install the radar module with its cable facing down to optimize both detection range and resistance to water ingress.

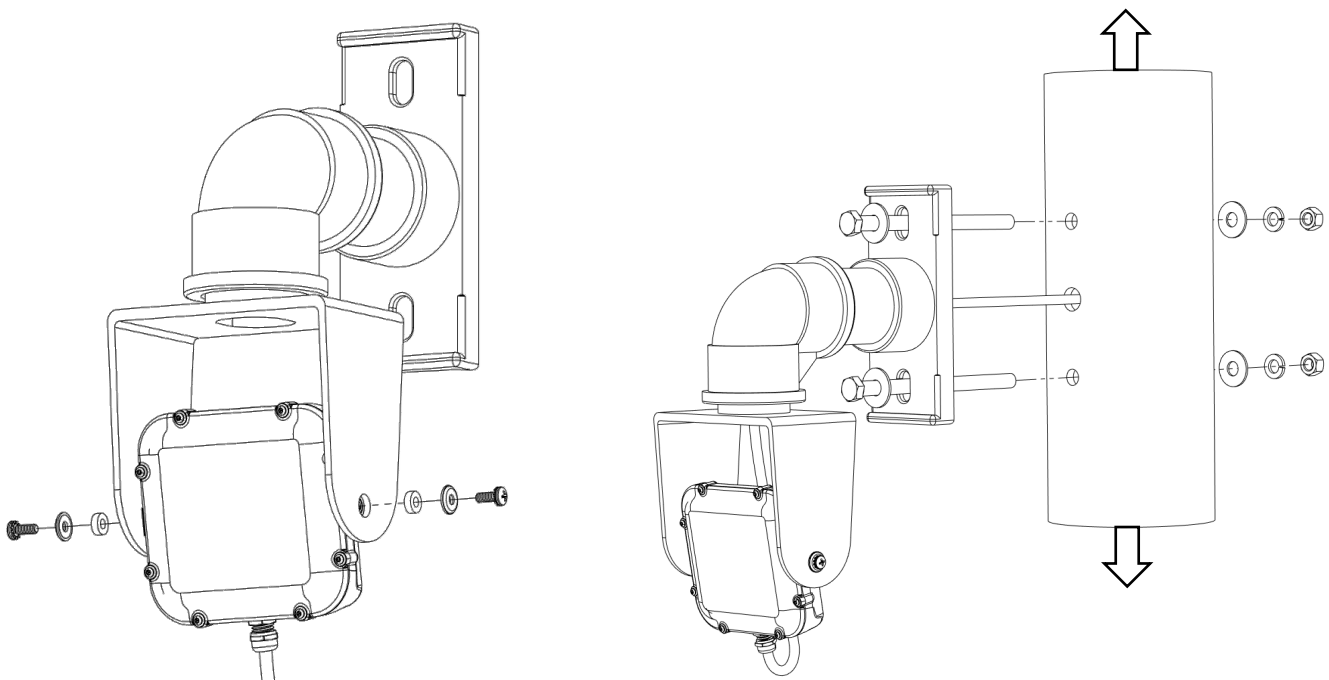

4.5 Aim Radar Module

Adjust the radar tilt and pan so its front face points directly at oncoming traffic. Tighten the hardware firmly to lock it in place.

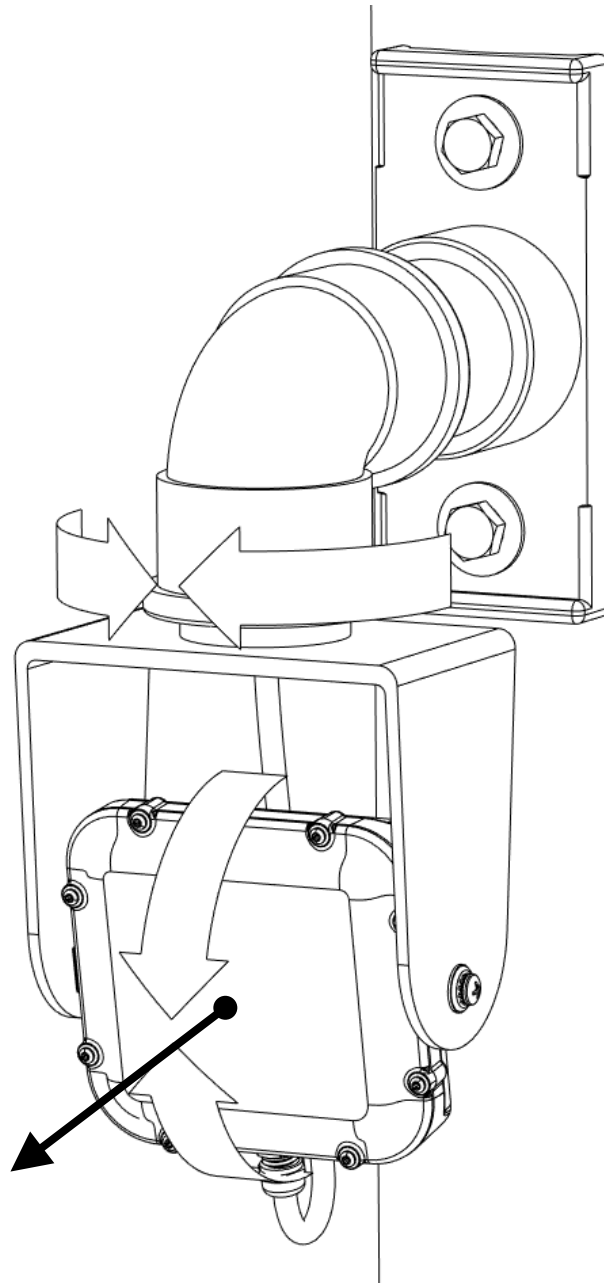

4.6 Connect and Configure Radar Module

Plug the radar cable connector onto its mate on the Radar Detection PCBA within the Carmanah E, F or G system. Turn the barrel firmly clockwise to lock the connectors together.

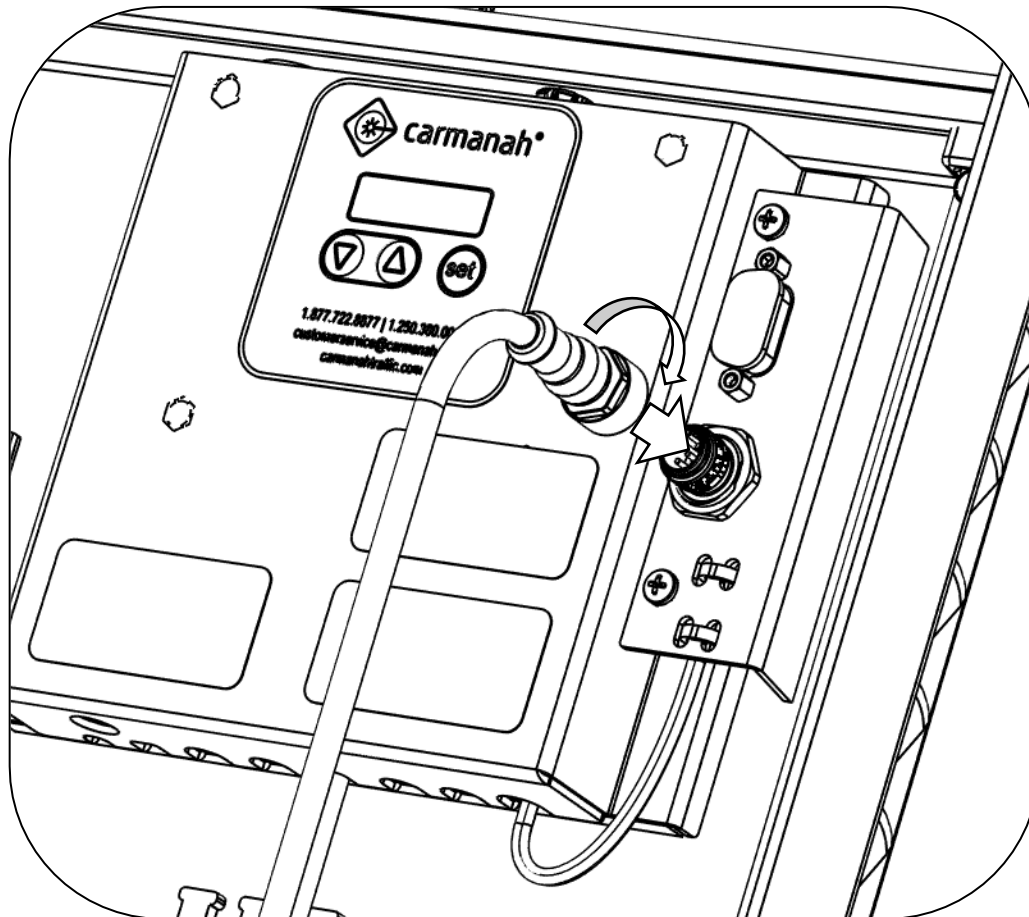
**NOTE**

The radar module is configured from the factory to trigger an activation whenever an oncoming vehicle is detected approaching at a speed of at least 5 mph (8 km/h).

Changes from the default settings are often unnecessary. Reasons for changing the radar's configuration include:

- To change the duration the LEDs flash following the last vehicle activation
- To change the detection speed limits (the minimum and maximum speeds that will trigger an activation)
- To increase or decrease the sensitivity of the radar module
- You've ordered the Advanced Statistics option and wish to configure data logging options or read traffic statistics from the radar module
- To configure the radar module for a less common application (e.g., a radar-activated minimum speed sign)

If it is necessary to configure the radar module, see [Section 6.0 Radar Module Connection & Settings](#).

4.7 Test System

Ensure that the Carmanah E/F/G system to which the radar kit is connected is powered up. See the Carmanah E/F/G Series User Manual at support.carmanah.com for details.

Test that the system activates as desired when vehicles approach the pole onto which the radar detection kit has been installed. If the LED loads fail to turn on, check the following:

- Nothing is obstructing the radar module's view of oncoming traffic
- The radar module is aimed directly at oncoming vehicles
- The LED load turns on for five seconds when an LED Fixture Test is performed (see below)

See the Troubleshooting section if the loads still fail to activate.

To perform the LED Fixture Test on the Carmanah EMS:

NOTE

- Use the up/down buttons on the EMS until “ל ע ע ל” is displayed
- Press and hold the “set” button until “no” flashes
- Press up or down once so that “ל ע ע ל” flashes
- Press and hold set; fixtures should turn on for 5 seconds

NOTE

When the radar module detects a vehicle, it shorts the button input terminals on the Carmanah EMS, turning on any connected LED loads. Once the vehicle motion is no longer detected, the radar module continues to short the EMS button input for its Output Hold Time setting, see [Section 6.4](#). This keeps the local LEDs and any remote wireless LEDs flashing for this duration after the vehicle stops being detected.

NOTE

Any E/F/G EMS with the radar detection kit installed should be left at Input Type “ר-ר” (normally open).

5.0 Maintenance and Product Care

The Radar Detection Kit is designed to operate reliably for years with virtually no need for maintenance.

Carmanah recommends routine inspections to ensure that the radar module and the connected Carmanah E, F or G system is unobstructed by anything that may prevent effective performance, including:

- Dirt and dust
- Snow
- Leaves
- Debris
- Shade that may have developed after installation due to adjacent plant growth.

The frequency of the inspections depends on location and local weather patterns. A yearly visual inspection of the system is typically enough. The system is designed to be maintenance free, but maximum system performance is achieved when the LED lenses and solar panels are clean. When inspecting the interior of the E/F/G system, ensure that the vent screens are undamaged and that the vents are clear and allow airflow.

6.0 Radar Module Connection & Settings

To change the system's activation behavior, configuration adjustments can be made to the radar module. Before making radar module configuration changes, please note the following:

- Detection range with factory default settings is typically at least 200 ft (60m)
- Aiming the radar module downwards and/or toward the road slightly can result in later activation
- Aiming the radar module upwards and/or farther up the road slightly can result in earlier activation

To make configuration changes, the following components are required:

- Windows 7, 8 or 10 PC (32-or 64-bit versions are supported) running the Houston Radar Advanced Stats Analyzer program (free download from <https://www.houston-radar.com>)
- An available USB-A port on the PC
- Radar Detection Programming Kit (provided), consisting of USB-to-Serial adapter and active USB extension cable
- Powered-up Carmanah E, F or G system with Radar Detection Kit installed and radar module connected

NOTE

The radar module is powered by the Carmanah E, F or G system to which it is connected. To be configured using the programming kit, the radar module must be connected to an operating Carmanah E, F or G system.



More information about radar module settings can be found in the Houston Radar DR600 User Manual available at <https://www.houston-radar.com>. To avoid unintended operation and/or excessive power consumption, configuration changes should be limited to those discussed in this section. Other settings should be left at their default values.

NOTE

Contact Carmanah for assistance with any configuration settings not discussed in this manual.

6.1 Connecting to the Radar Module

1. Remove the dust cap from the DB9 connector within the Carmanah E, F or G system.

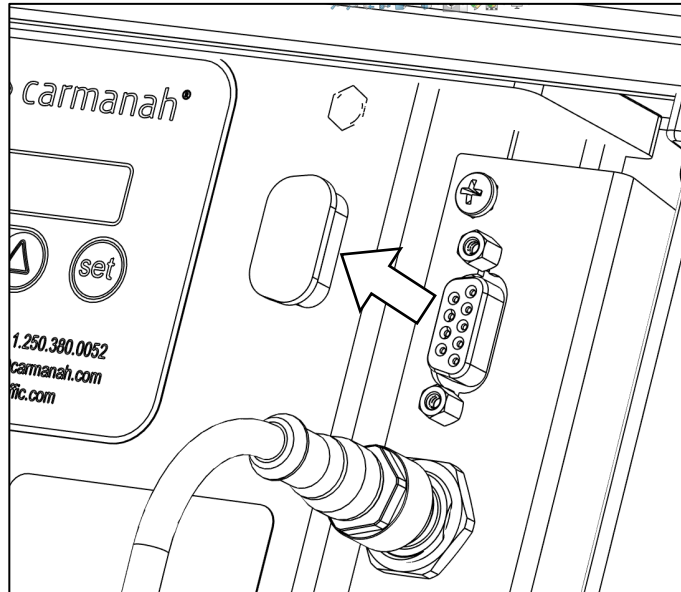

2. Plug the USB-to-Serial adapter into the DB9 connector within the Carmanah E, F or G system.
3. Plug one end of the USB extension into the USB-to-Serial adapter, and the other end into the USB port of the PC.
4. Start the Advanced Stats Analyzer program.
5. Select the "Connect to Radar" option from the top banner.
6. Click the "Connect to Radar" button. (Software scans ports until radar found.)
7. Ensure you see a "Radar Found on..." message.
8. Click "OK".

NOTE

The radar module is powered by the Carmanah E, F or G system to which it is connected. To be configured using the programming kit, the radar module must be connected to an operating Carmanah E, F or G system.



More information about radar module settings can be found in the Houston Radar DR600 User Manual, available at <https://www.houston-radar.com>. To avoid unintended operation and/or excessive power consumption, configuration changes should be limited to those discussed in this section. Other settings should be left at their default values.



Adjusting settings not outlined in this section may adversely affect radar detection performance.

NOTE

Contact Carmanah for assistance with any configuration settings not discussed in this manual.

6.2 Syncing radar clock to computer

It is recommended that you click the “Sync Radar Clock to Computer” whenever you connect to a radar module. This is done by clicking the button from the Connection tab of the Connect to Radar window:

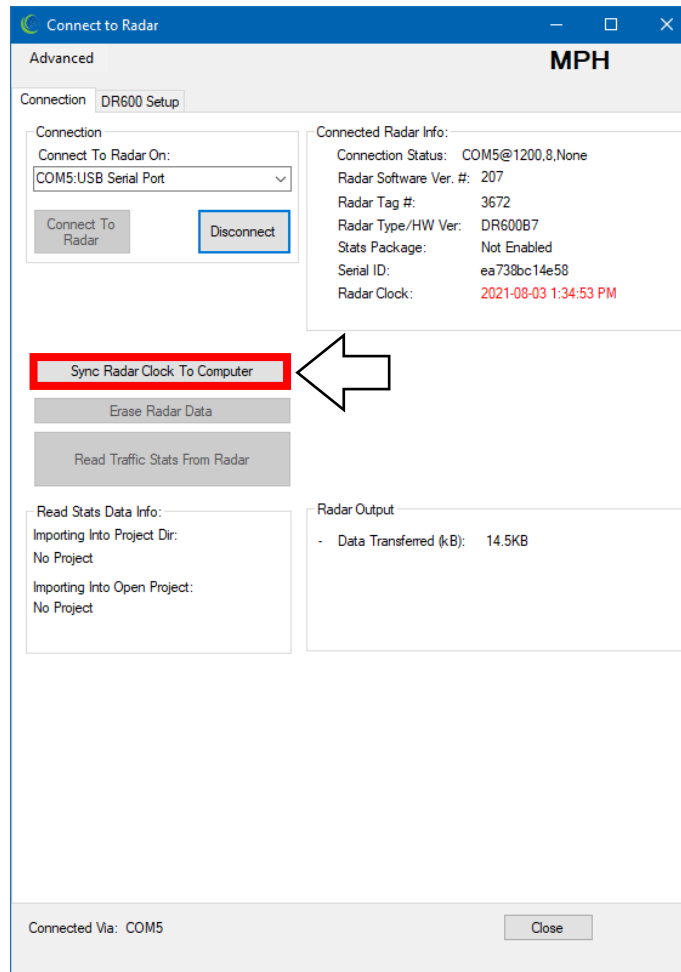

After a few moments, the Radar Clock listed will match the computer's clock.

6.3 Adjusting Speed Detection Limits and Sensitivity

Under the “DR600 Setup,” the “Detection & Units” tab are speed settings that influence the system’s activation behavior:

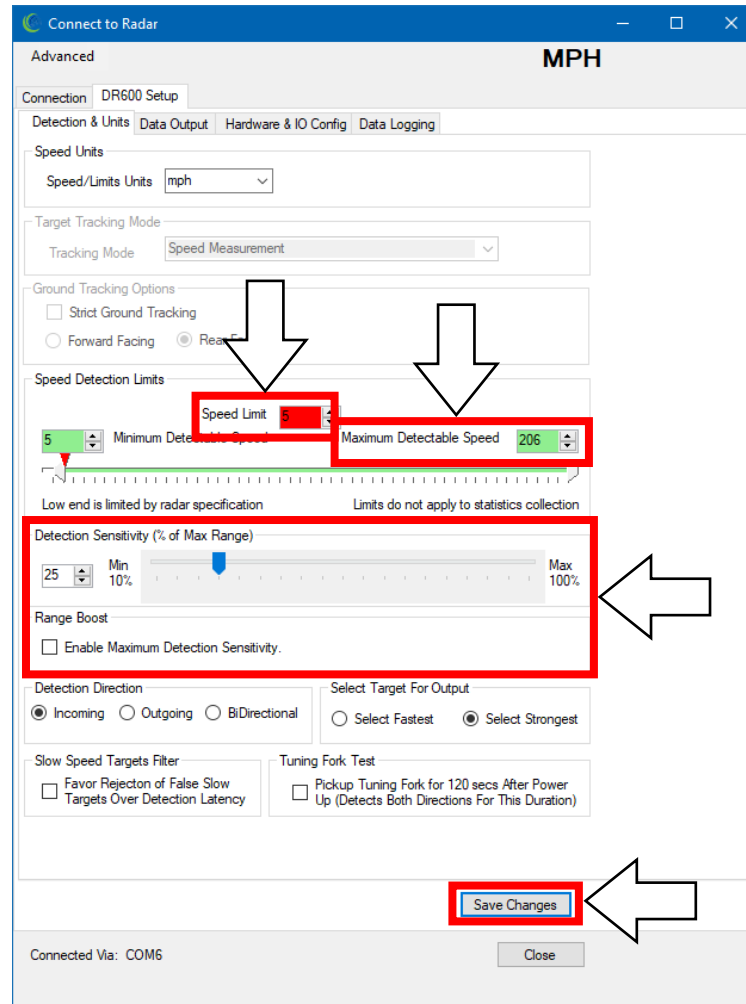

Speed Limit: vehicles travelling above or below this speed (depending on the “Trigger Event” setting) will trigger an activation of the connected Carmanah E/F/G system. Default setting is 5 mph.

Maximum Detectable Speed: vehicles travelling above this speed will not trigger an activation of the connected Carmanah E/F/G system. Default setting is 206 mph.

Detection Sensitivity: the sensitivity of the radar can be tuned with this setting. This can be helpful if the system is being triggered by vehicles other than those targeted, or if you wish the system to activate when vehicles are a greater distance away. Default setting is 25%.

Range Boost: increases the distance at which vehicles are detected. Undesired detection of vehicles may result from enabling Range Boost. Default is off.

NOTE

Click on “Save Changes” to save the changes to the radar module, or “Close” to disconnect from the radar module without saving.

6.4 Adjusting Trigger Output Configuration

Under the “DR600 Setup”, “Hardware & IO Config” tab are settings that control the system’s activation behavior:

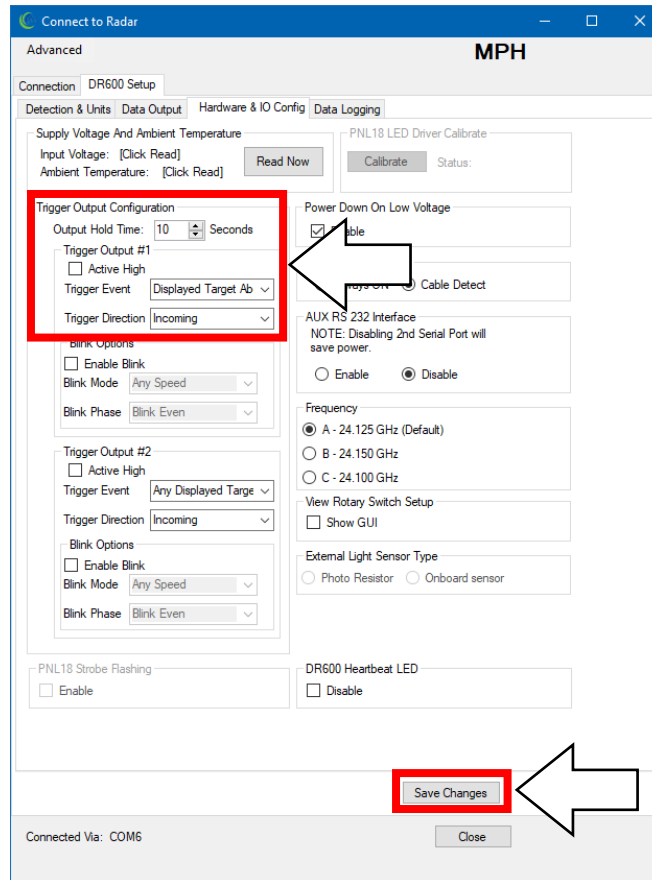

Output Hold Time: this setting controls how long the local (and any remote wirelessly-connected) Carmanah E/F/G system(s) continue to flash after the radar module stops sensing vehicle motion. Default is 10 seconds. To avoid erratic flashing, this setting should not be set below 5 seconds.

Trigger Event: this setting changes the conditions under which an activation of the connected Carmanah E/F/G system is triggered:

- **None:** no activations will occur.
- **Default: Displayed Target Above Speed Limit (default setting):** Carmanah E/F/G system activated when vehicle detected above configured Speed Limit on “Detection & Units” tab.
- **Displayed Target Below Speed Limit:** Carmanah E/F/G system activated when vehicle detected below configured Speed Limit on “Detection & Units” tab.
- **Any Displayed Target:** Carmanah E/F/G system activated whenever a vehicle is detected, regardless of speed.

Trigger Direction: this setting changes whether incoming vehicles, outgoing vehicles, or both will trigger the connected Carmanah E/F/G system. Default setting is Incoming.

NOTE

Click on “Save Changes” to save the changes to the radar module, or “Close” to disconnect from the radar module without saving.

7.0 Troubleshooting

Symptom	Possible Cause and What to Check
LED fixtures fail to turn on when a vehicle approaches.	<ol style="list-style-type: none"> Object obstructing radar path: <ul style="list-style-type: none"> Ensure nothing is obstructing the radar module's view of target traffic. Radar not aimed correctly: <ul style="list-style-type: none"> Ensure radar module is pointing directly at target traffic. Radar module not connected properly: <ul style="list-style-type: none"> Ensure circular connector is mated in Carmanah E/F/G system and barrel is firmly tightened. Problem with connected Carmanah E/F/G system: <ul style="list-style-type: none"> Confirm connected Carmanah E/F/G system is powered up and operating correctly; perform LED fixture test and see E/F/G user manual for more information. Radar module improperly configured: <ul style="list-style-type: none"> Connect to radar module and check settings (see Section 6.0).
LED fixtures turn on when there is no traffic approaching.	<ol style="list-style-type: none"> Radar being triggered by unintended object movement: <ul style="list-style-type: none"> Ensure there are no fans or other moving objects in direction radar is pointed. Other Carmanah E/F/G system causing activation: <ul style="list-style-type: none"> Ensure nearby systems in a different group are set to a different channel (see Carmanah E/F/G manual).
LED fixtures turn on too early (when vehicle too far away).	<ol style="list-style-type: none"> Radar aimed too high and/or too far up road: <ul style="list-style-type: none"> Aim radar module down and/or more toward road. Radar sensitivity set too high: <ul style="list-style-type: none"> Reduce radar sensitivity setting (see Section 6.3). Disable Maximum Detection Sensitivity setting (see Section 6.3).
LED fixtures turn on too late (when vehicle too close).	<ol style="list-style-type: none"> Radar module dirty or obstructed: <ul style="list-style-type: none"> Ensure radar module is clean and that nothing is obstructing its view of traffic. Radar aimed too low and/or too far in toward road: <ul style="list-style-type: none"> Aim radar up and/or farther up the road toward oncoming traffic. Radar sensitivity set too low: <ul style="list-style-type: none"> Increase radar sensitivity setting (see Section 6.3).
LED fixtures on for too long/short a duration after vehicle detected.	<ol style="list-style-type: none"> Output Hold Time setting needs to be adjusted on radar module: <ul style="list-style-type: none"> Adjust "Output Hold Time" setting on radar module (see Section 6.4)
LED fixtures triggered by outgoing vehicles.	<ol style="list-style-type: none"> Radar module configured to detect outgoing vehicles: <ul style="list-style-type: none"> Ensure "Trigger Direction" setting on radar module is configured correctly (see Section 6.4).

Symptom	Possible Cause and What to Check
LED fixtures activating inconsistently.	<ol style="list-style-type: none"> 1. Radar module dirty or obstructed: <ul style="list-style-type: none"> • Ensure radar module is clean and that nothing is obstructing its view of traffic. 2. Radar sensitivity set too low: <ul style="list-style-type: none"> • Increase radar sensitivity setting (see Section 6.3). 3. Radar “Speed Limit” set incorrectly: <ul style="list-style-type: none"> • Adjust “Speed Limit” setting (see Section 6.3). 4. Radar “Trigger Event” set incorrectly: <ul style="list-style-type: none"> • Adjust “Trigger Event” setting (see Section 6.4).
Remote wireless systems do not activate; local system activates when a vehicle approaches.	<ol style="list-style-type: none"> 1. Wireless systems set to different channels: <ul style="list-style-type: none"> • Ensure all units are set to same Radio Channel using OBUI. See EMS Programming and Testing section of Carmanah E/F/G manual. 2. Wireless systems too far apart: <ul style="list-style-type: none"> • Ensure units are not too far apart: ideal, 500 ft (152 m); maximum, 1,000 ft (305 m) unobstructed line of sight. 3. Objects obstructing wireless communication between units: <ul style="list-style-type: none"> • Check for barriers or obstructions between systems such as buildings or billboards.
LED fixtures not flashing in desired manner.	<ol style="list-style-type: none"> 1. Connected Carmanah E/F/G system configuration needs adjustment: <ul style="list-style-type: none"> • Adjust Carmanah E/F/G systems to have desired flash behavior using the OBUI. See EMS Programming and Testing section of Carmanah E/F/G manual.



© 2021 Carmanah Technologies Corporation

Technical Support:

Email: customersupport@carmanah.com

Toll Free: 1.877.722.8877 (US & Canada)

Worldwide: 1.250.380.0052

Fax: 1.250.380.0062

Web: carmanah.com