

**NOTE** SIM card comes preactivated. Only Carmanah-supplied SIM cards can be used with this product.

1. Disconnect power to system:
  - Solar only: remove solar connector and then battery connector(s).
  - MX 300 AC Cabinet Module: open fuse holder.
  - MX 400 AC Cabinet Module: turn off breaker.

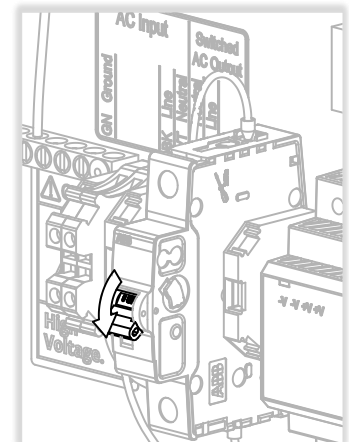

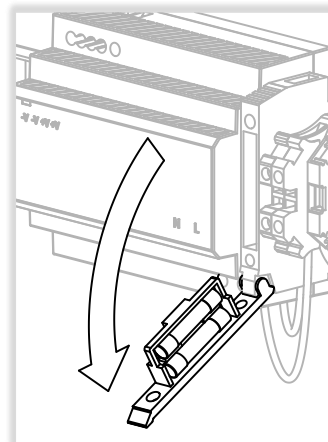
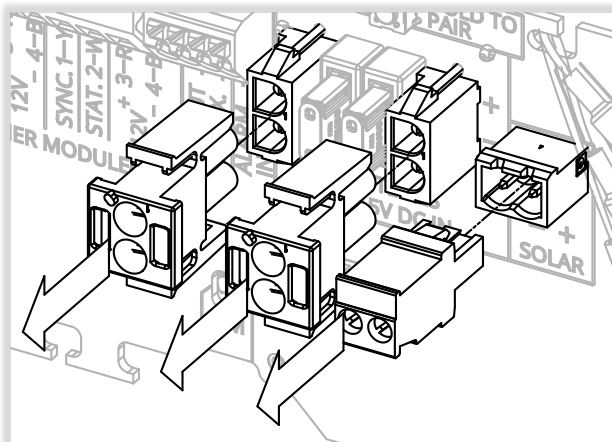

2. Open the new SIM card package. The SIM card is embedded onto a triple-cut adapter. Snap out the SIM card to its smallest form (nano SIM).
3. Place rag under SIM card location to catch SIM card to avoid losing it.
4. Using a small spudger, toothpick or similar non-metallic tool inserted into square opening shown, gently slide SIM card down and out of its holder.
5. SIM card should now be sticking out enough to pull it out with your thumb and index finger.

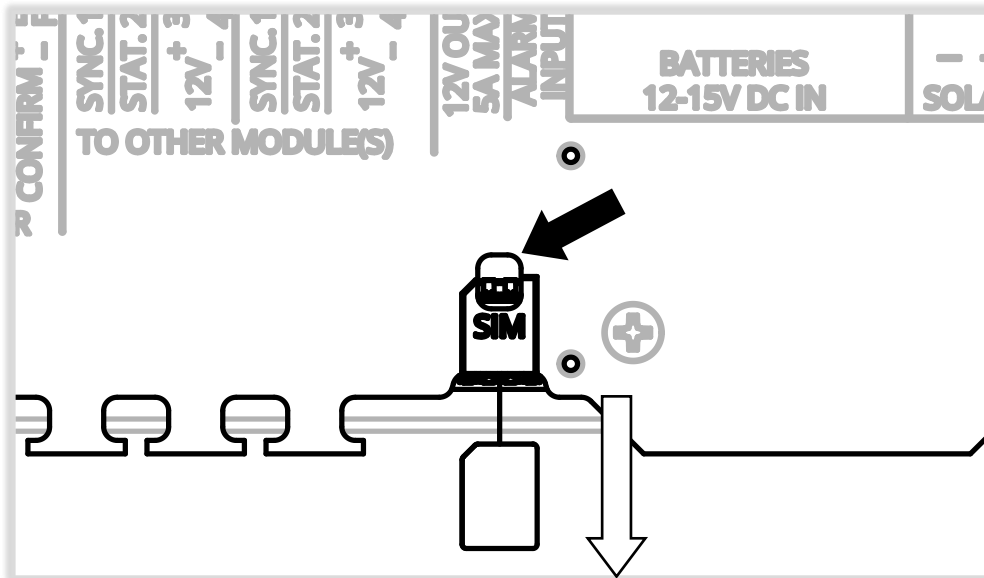

6. Orient replacement SIM card as shown and insert into holder.
7. Reconnect power to system.
8. System will start communicating with MX Cloud shortly after establishing a connection. If you have MX Cloud access confirm the system is now reporting in.



**Use extreme care when inserting the new SIM card. Applying too much force will damage the SIM card holder and prevent network connectivity.**

